

NCD

Network Control Display

INSTRUCTION MANUAL

LS10210-051NF-E

ECN: 00056813

Rev: H | November 2024

Honeywell International Inc. (“HII”) reserves the right to make changes in specifications and other information contained in this document without prior notice, and the reader should in all cases consult HII to determine whether any such changes have been made. The information in this publication does not represent a commitment on the part of HII.

HII shall not be liable for technical or editorial errors or omissions contained herein; nor for incidental or consequential damages resulting from the furnishing, performance, or use of this material. HII disclaims all responsibility for the selection and use of software and/or hardware to achieve intended results.

This document contains proprietary information that is protected by copyright. All rights are reserved. No part of this document may be photocopied, reproduced, or translated into another language without the prior written consent of HII.

Copyright ©2024 Honeywell International Inc. All rights reserved.

Web Address: <https://buildings.honeywell.com/>

Other product names or marks mentioned in this document may be trademarks or registered trademarks of other companies and are the property of their respective owners.

FIRE ALARM & EMERGENCY COMMUNICATION SYSTEM LIMITATIONS

While a life safety system may lower insurance rates, it is not a substitute for life and property insurance!

An automatic fire alarm system—typically made up of smoke detectors, heat detectors, manual pull stations, audible warning devices, and a fire alarm control panel (FACP) with remote notification capability—can provide early warning of a developing fire. Such a system, however, does not assure protection against property damage or loss of life resulting from a fire.

An emergency communication system—typically made up of an automatic fire alarm system (as described above) and a life safety communication system that may include an autonomous control unit (ACU), local operating console (LOC), voice communication, and other various interoperable communication methods—can broadcast a mass notification message. Such a system, however, does not assure protection against property damage or loss of life resulting from a fire or life safety event. The Manufacturer recommends that smoke and/or heat detectors be located throughout a protected premises following the recommendations of the current edition of the National Fire Protection Association Standard 72 (NFPA 72), manufacturer’s recommendations, State and local codes, and the recommendations contained in the Guide for Proper Use of System Smoke Detectors, which is made available at no charge to all installing dealers. This document can be found at <http://www.systemsensor.com/appguides/>. A study by the Federal Emergency Management Agency (an agency of the United States government) indicated that smoke detectors may not go off in as many as 35% of all fires. While fire alarm systems are designed to provide early warning against fire, they do not guarantee warning or protection against fire. A fire alarm system may not provide timely or adequate warning, or simply may not function, for a variety of reasons:

Smoke detectors may not sense fire where smoke cannot reach the detectors such as in chimneys, in or behind walls, on roofs, or on the other side of closed doors. Smoke detectors also may not sense a fire on another level or floor of a building. A second-floor detector, for example, may not sense a first-floor or basement fire. Particles of combustion or “smoke” from a developing fire may not reach the sensing chambers of smoke detectors because:

- Barriers such as closed or partially closed doors, walls, chimneys, even wet or humid areas may inhibit particle or smoke flow.
- Smoke particles may become “cold,” stratify, and not reach the ceiling or upper walls where detectors are located.
- Smoke particles may be blown away from detectors by air outlets, such as air conditioning vents.
- Smoke particles may be drawn into air returns before reaching the detector.

The amount of “smoke” present may be insufficient to alarm smoke detectors. Smoke detectors are designed to alarm at various levels of smoke density. If such density levels are not created by a developing fire at the location of detectors, the detectors will not go into alarm. Smoke detectors, even when working properly, have sensing limitations. Detectors that have photoelectronic sensing chambers tend to detect smoldering fires better than flaming fires, which have little visible smoke. Detectors that have ionizing-type sensing chambers tend to detect fast-flaming fires better than smoldering fires. Because fires develop in different ways and are often unpredictable in their growth, neither type of detector is necessarily best and a given type of detector may not provide adequate warning of a fire.

Smoke detectors cannot be expected to provide adequate warning of fires caused by arson, children playing with matches (especially in bedrooms), smoking in bed, and violent explosions (caused by escaping gas, improper storage of flammable materials, etc.).

Heat detectors do not sense particles of combustion and alarm only when heat on their sensors increases at a predetermined rate or reaches a predetermined level. Rate-of-rise heat detectors may be subject to reduced sensitivity over time. For this reason, the rate-of-rise feature of each detector should be tested at least once per year by a qualified fire protection specialist. Heat detectors are designed to protect property, not life.

IMPORTANT! Smoke detectors must be installed in the same room as the control panel and in rooms used by the system for the connection of alarm transmission wiring, communications, signaling, and/or power. If detectors are not so located, a developing fire may damage the alarm system, compromising its ability to report a fire.

Audible warning devices such as bells, horns, strobes, speakers and displays may not alert people if these devices are located on the other side of closed or partly open doors or are located on another floor of a building. Any warning device may fail to alert people with a disability or those who have recently consumed drugs, alcohol, or medication. Please note that:

- An emergency communication system may take priority over a fire alarm system in the event of a life safety emergency.
- Voice messaging systems must be designed to meet intelligibility requirements as defined by NFPA, local codes, and Authorities Having Jurisdiction (AHJ).
- Language and instructional requirements must be clearly disseminated on any local displays.
- Strobes can, under certain circumstances, cause seizures in people with conditions such as epilepsy.
- Studies have shown that certain people, even when they hear a fire alarm signal, do not respond to or comprehend the meaning of the signal. Audible devices, such as horns and bells, can have different tonal patterns and frequencies. It is the property owner’s responsibility to conduct fire drills and other training exercises to make people aware of fire alarm signals and instruct them on the proper reaction to alarm signals.
- In rare instances, the sounding of a warning device can cause temporary or permanent hearing loss.

A life safety system will not operate without any electrical power. If AC power fails, the system will operate from standby batteries only for a specified time and only if the batteries have been properly maintained and replaced regularly.

Equipment used in the system may not be technically compatible with the control panel. It is essential to use only equipment listed for service with your control panel.

Alarm Signaling Communications:

- **IP connections** rely on available bandwidth, which could be limited if the network is shared by multiple users or if ISP policies impose restrictions on the amount of data transmitted. Service packages must be carefully chosen to ensure that alarm signals will always have available bandwidth. Outages by the ISP for maintenance and upgrades may also inhibit alarm signals. For added protection, a backup cellular connection is

recommended.

- **Cellular connections** rely on a strong signal. Signal strength can be adversely affected by the network coverage of the cellular carrier, objects and structural barriers at the installation location. Utilize a cellular carrier that has reliable network coverage where the alarm system is installed. For added protection, utilize an external antenna to boost the signal.
- **Telephone lines** needed to transmit alarm signals from a premise to a central monitoring station may be out of service or temporarily disabled. For added protection against telephone line failure, backup alarm signaling connections are recommended.

The most common cause of life safety system malfunction is inadequate maintenance. To keep the entire life safety system in excellent working order, ongoing maintenance is required per the manufacturer's recommendations, and UL and NFPA standards. At a minimum, the requirements of NFPA 72 shall be followed. Environments with large amounts of dust, dirt, or high air velocity require more frequent maintenance. A maintenance agreement should be arranged through the local manufacturer's representative. Maintenance should be scheduled as required by National and/or local fire codes and should be performed by authorized professional life safety system installers only.

INSTALLATION PRECAUTIONS

Adherence to the following will aid in problem-free installation with long-term reliability:

WARNING - Several different sources of power can be connected to the fire alarm control panel. Disconnect all sources of power before servicing. Control unit and associated equipment may be damaged by removing and/or inserting cards, modules, or interconnecting cables while the unit is energized. Do not attempt to install, service, or operate this unit until manuals are read and understood.

CAUTION - System Re-acceptance Test after Software Changes:

To ensure proper system operation, this product must be tested in accordance with NFPA 72 after any programming operation or change in site-specific software. Re-acceptance testing is required after any change, addition or deletion of system components, or after any modification, repair or adjustment to system hardware or wiring. All components, circuits, system operations, or software functions known to be affected by a change must be 100% tested. In addition, to ensure that other operations are not inadvertently affected, at least 10% of initiating devices that are not directly affected by the change, up to a maximum of 50 devices, must also be tested and proper system operation verified.

This system meets NFPA requirements for operation at 0-49° C/32-120° F and at a relative humidity 93% ± 2% RH (non-condensing) at 32°C ± 2°C (90°F ± 3°F). However, the useful life of the system's standby batteries and the electronic components may be adversely affected by extreme temperature ranges and humidity. Therefore, it is recommended that this system and its peripherals be installed in an environment with a normal room temperature of 15-27° C/60-80° F.

Verify that wire sizes are adequate for all initiating and indicating device loops. Most devices cannot tolerate more than a 10% I.R. drop from the specified device voltage.

Like all solid state electronic devices, this system may operate erratically or can be damaged when subjected to lightning induced transients. Although no system is completely immune from lightning transients and interference, proper grounding will reduce susceptibility. Overhead or outside aerial wiring is not recommended, due to an increased susceptibility to nearby lightning strikes. Consult with the Technical Services Department if any problems are anticipated or encountered.

Disconnect AC power and batteries prior to removing or inserting circuit boards. Failure to do so can damage circuits.

Remove all electronic assemblies prior to any drilling, filing, reaming, or punching of the enclosure. When possible, make all cable entries from the sides or rear. Before making modifications, verify that they will not interfere with battery, transformer, or printed circuit board location.

Do not tighten screw terminals more than 9 in-lbs. Over-tightening may damage threads, resulting in reduced terminal contact pressure and difficulty with screw terminal removal.

This system contains static-sensitive components. Always ground yourself with a proper wrist strap before handling any circuits so that static charges are removed from the body. Use static suppressive packaging to protect electronic assemblies removed from the unit.

Units with a touchscreen display should be cleaned with a dry, clean, lint free/microfiber cloth. If additional cleaning is required, apply a small amount of Isopropyl alcohol to the cloth and wipe clean. Do not use detergents, solvents, or water for cleaning. Do not spray liquid directly onto the display.

Follow the instructions in the installation, operating, and programming manuals. These instructions must be followed to avoid damage to the control panel and associated equipment. FACP operation and reliability depend upon proper installation.

HARSH™, NIS™, and NOTI•FIRE•NET™ are all trademarks; and Acclimate® Plus™, FlashScan®, FFAST Fire Alarm Aspiration Sensing Technology®, Honeywell®, INSPIRE®, Intelligent FFAST®, NOTIFIER®, ONYX®, ONYXWorks®, SWIFT®, VeriFire®, are all registered trademarks of Honeywell International Inc. Microsoft® and Windows® are registered trademarks of the Microsoft Corporation. Chrome™ and Google™ are trademarks of Google Inc. Firefox® is a registered trademark of The Mozilla Foundation.

©2024 by Honeywell International Inc. All rights reserved. Unauthorized use of this document is strictly prohibited.

SOFTWARE DOWNLOADS

In order to supply the latest features and functionality in fire alarm and life safety technology to our customers, we make frequent upgrades to the embedded software in our products. To ensure that you are installing and programming the latest features, we strongly recommend that you download the most current version of software for each product prior to commissioning any system.

Contact Technical Support with any questions about software and the appropriate version for a specific application.

DOCUMENTATION FEEDBACK

Your feedback helps us keep our documentation up-to-date and accurate. If you have any comments or suggestions about our online

Help or printed manuals, you can email us.

Please include the following information:

- Product name and version number (if applicable)
- Printed manual or online Help
- Topic Title (for online Help)
- Page number (for printed manual)
- Brief description of content you think should be improved or corrected
- Your suggestion for how to correct/improve documentation

Send email messages to:

FireSystems.TechPubs@honeywell.com

Please note this email address is for documentation feedback only. If you have any technical issues, please contact Technical Services.

TABLE OF CONTENTS

SECTION 1: ABOUT THIS MANUAL	1
1.1 Standards and Specifications	1
1.2 UL 864 Tenth Edition Compliance	1
1.3 Programming Features Subject to AHJ Approval	2
1.4 Related Documentation	2
1.5 Compatibility with NOTI•FIRE•NET™ Panel Nodes	4
1.6 General Description Conventions	4
1.7 Overview	5
1.8 Features	5
1.9 NCD Display	6
1.9.0.1. Menu Main Window Button	6
1.9.0.2. User Login Button	6
1.9.0.3. Header Bar	6
1.9.0.4. Instructional Text Area	6
1.9.0.5. Alert Bar	6
1.9.0.6. Events List	7
1.10 Licensing	7
1.11 Technical Specifications	8
1.11.1. Power Input:	8
1.11.2. USB Ports:	8
1.11.3. Touch Screen Display:	8
1.11.4. Current draw:	8
1.11.5. Tamper and Trouble Input:	8
1.11.6. Trouble Relay:	8
SECTION 2: INSTALLATION	9
2.1 Preparing for Installation	9
2.1.1. Installation Checklist	9
2.2 CAB-4 and CAB-5 Series Cabinets	12
2.3 Installing the NCD on ONYX Series panels Mounting the NCD on the NFS2-3030	14
2.3.1. Using the NCD as Primary Display on the NFS2-640 and NFS-320SYS	15
2.3.2. NFS-320/SYS and NFS2-640 Mounting	16
2.4 Dress Plate Mounting	17
2.5 Wiring AIO Bus Devices to the NCD	18
2.5.1. Termination Resistors	20
2.5.2. End-of-Line Resistors on the ACM-30	20
2.5.3. Addressing the ACM-30	20
2.5.4. End-of-Line Resistors on the RLD	21
2.5.5. Addressing the RLD	21
2.6 Board Layout and Wiring Requirements	21
2.6.1. Ground Screw Locations	23
2.6.2. Even Indicator Locations	24
2.6.3. Piezo Enable/Disable	24

SECTION 3: PROGRAMMING	26
3.1 USB Port C	26
3.2 Password Requirements	26
3.3 Menu Navigation	27
3.3.1. Settings	27
3.3.2. Programming	27
3.3.3. Custom Actions	27
3.3.4. Point Information	27
3.3.5. Drill	27
3.3.6. Disable Points/Functions	28
3.3.7. Test/Diagnostics	28
3.3.8. Settings	28
3.3.9. Programming	28
3.3.10.	30
3.3.11. User Login	31
3.3.11.1. Adding and Removing a User	31
3.3.11.2. Changing the Password	32
3.3.11.3. Levels of Programing Access	33
3.3.11.4. Regional Settings	35
3.4 Test/Diagnostics	35
3.4.1. Diagnostics	35
3.4.2. Lamp Test	36
3.4.3. View History	36
3.4.4. Export Diagnostics	36
3.4.5. Clear Database	36
3.4.6. Clear Licenses	36
3.4.7. Reboot	36
3.5 Custom Actions	37
3.5.1. Enable Points	38
3.5.2. Turn ON/OFF points	38
SECTION 4: OPERATION	39
4.1 Responding to a Fire Alarm	39
4.2 Carbon Monoxide Alarm	40
4.2.1. Responding to a Carbon Monoxide Alarm	40
4.3 Supervisory Activation	41
4.3.1. Responding to a Supervisory Activation	41
4.4 Trouble Event	42
4.4.1. Responding to a Trouble Event	43
4.5 Disabled Point	43
4.5.1. Responding to a Disabled Point	44
4.6 Other	44
4.6.1. Responding to an Other event	45
LS10216-151NF-E REV B	46

SECTION 1: ABOUT THIS MANUAL

1.1 STANDARDS AND SPECIFICATIONS

The NCD has been designed to comply with standards set forth by the following regulatory agencies:

- Underwriters Laboratories Standard UL 864
- UL 2610 Commercial Premises Security Alarm Units and Systems
- Underwriters Laboratories Standard UL 2017 for General-Purpose Signaling Devices and Systems
- NFPA 72 National Fire Alarm Code

The contents of this manual are important and must be kept in close proximity of the hardware. If building ownership is changed, this manual and all other testing and maintenance information must also be passed to the current owner of the facility. A copy of this manual was shipped with the equipment and is also available from the manufacturer.



WARNING! Improper installation, maintenance, or lack of routine testing could result in system malfunction.



CAUTION: Read all bundled documentation for detailed instructions on upgrade/downgrade installation information.



WARNING! Do not connect or disconnect the oculink cable between the core and Dim boards (upper and lower boards) while power is applied to prevent system damage.

1.2 UL 864 TENTH EDITION COMPLIANCE



This product has been certified to comply with the requirements in the Standard for Control Units and Accessories for Fire Alarm Systems, UL 864 10th Edition.

Operation of the NCD with products not tested for UL 864 9th Edition has not been evaluated and may not comply with NFPA 72 and/or the latest edition of UL 864. These applications will require the approval of the local Authority Having Jurisdiction (AHJ).

UL 10th Edition
NFS-320
NFS2-640
NFS2-3030
NCA-2
N16e
N16x

1.3 PROGRAMMING FEATURES SUBJECT TO AHJ APPROVAL

This product incorporates field-programmable software. The features and/or options listed below must be approved by the local AHJ.

This product incorporates field-programmable software. In order for the product to comply with the requirements in the Standard for Control Units and Accessories for Fire Alarm Systems, UL 864 certain programming features or options must be limited to specific values or not used at all as indicated below.

Program Feature or Option	Permitted in UL 864? (Y/N)	Possible Settings	Settings Permitted in UL 864
Trouble Reminder	Yes	4 Hours 24 Hours	24 Hours
Alarm Reminder	Yes	0-24 Hours	1-24 Hours
Supervisory Reminder	Yes	0-24 Hours	1-24 Hours
CO Reminder	Yes	0-24 Hours	1-24 Hours

1.4 RELATED DOCUMENTATION

The table below provides a list of documents referenced in this manual, as well as documents for selected other compatible devices.

Compatible Conventional Devices (Non-addressable)	Document Number
Device Compatibility Document	15378
Off-line Programming Utility	Document Number
VeriFire™ Tools CD help file	Available for download on www.notifier.com
Cabinets & Chassis	Document Number
CAB-5 Series Cabinet Installation Document	LS10244-000GE-E

NBB-2 Installation Document	LS10250-000GE-E
ABB Installation Document	LS10249-000GE-E
CAB-3/CAB-4 Series Cabinet Installation Document	15330
Battery/Peripherals Enclosure Installation Document	50295
BMP-1 Blank Module Plate Installation Document	51008
Heat Dissipation for Cabinets with Digital Audio Products	53645
Control Panels and Power Supplies	Document Number
NFS2-3030ULLD	LS10006-051NF
N16 ULLD	LS10239-051NF-E
PMB-AUX	LS10242-000GE-E
NFS2-640/EULLD	52741LD
NFS-320SYSULLD	52745LD
AMPS-24/E Power Supply Manual	51907
ACPS-610 Addressable Power Supply Manual	53018
Networking	Document Number
Noti•Fire•Net Manual, Network Version 5.0 & Higher	51584
High Speed Noti•Fire•Net Manual	54013
NCM-W/F Installation Document	51533
HS-NCM High Speed Network Communications Module Installation Document	54014
ONYXWorks Manual	52342
System Components	Document Number
ACM-30 Annunciator Manual	LS10238-000GE-E
RLD Remote Display Manual	LS10310-000NF-E
DVC Digital Voice Command Manual	52411
DAL Devices Reference Sheet	52410
DS-DB Digital Series Distribution Board and Amplifier Manual	53622
DVC-RPU UL Listing Document	50107424-001
AA Series Audio Amplifier Manual	52526
DAA2 and DAX Amplifiers Manual	53265
SWIFT Gateway Manual	LS10036-00NF-E

Table 1.1: Related Documentation

 **NOTE:** Supplemental information for a topic, such as tips and references.

 **CAUTION:** Information about procedures that could cause programming errors, runtime errors, or equipment damage.

 **WARNING!** Indicates information about procedures that could cause irreversible equipment damage, irreversible loss of programming data or personal injury.

1.5 COMPATIBILITY WITH NOTI•FIRE•NET™ PANEL NODES

FACP	Network Board
NFS2-640	NCM-W/F, HS-NCM-W/W-2/SF/MF/WSF/WSF-2/WMF/MFSF
NFS-320	NCM-W/F, HS-NCM-W/SF/MF/WSF/WMF/MFSF
NFS2-3030	NCM-W/F, HS-NCM-W/SF/MF/WSF/WMF/MFSF
DVC Series	NCM-W/F, HS-NCM-W/SF/MF/WSF/WMF/MFSF
NCA-2	NCM-W/F, HS-NCM-W/W-2/SF/MF/WSF/WSF-2/WMF/WMF-2/MFSF
N16/NCD	NCM-W/F, HS-NCM-W/W-2/SF/MF/WSF/WSF-2/WMF/WMF-2/MFSF

 **NOTE:** To be compatible with the NC, all networked nodes must be running NOTI•FIRE•NET™ version 5.0 or higher or a high-speed NOTI•FIRE•NET™. The NCA-2 will not monitor events or control functions originating from the N16 N16 or NCD should not be added to the network map of an NCA-2 or NFS2-3030 in Network display mode.

Table 1.2: NOTI•FIRE•NET™ Compatible Fire Panels

1.6 GENERAL DESCRIPTION CONVENTIONS

This manual uses the following conventions as listed below:

When you see	Specifies	Example
Text in small caps	The text as it appears in the Touch Screen display or on the control panel	Co ALARM Co MONITOR FIRST FLOOR GUEST ROOM
Text in quotes	A reference to a section or a touch screen menu	“Status Change” specifies the Status Change section or menu screen
Italic text	A specific document	<i>“3.3.11. User Login” on page 31</i>

1.7 OVERVIEW

The NCD is a Network Control Display for High Speed or Standard NFN Networks. It offers a direct connect display for stand-alone ONYX panels (version 26 or higher), and the DVC. It has a High Definition 10 inch color touch screen display, and is capable of displaying up to 3,000 events.

1.8 FEATURES

The NCD incorporates the following features:

- List of active events organized by status, event type and event time
- Configurable Alert Bar with color coded event icons indicating the status and event counts
- Fire Alarm, CO Alarm, Supervisory, Trouble, and Disable Event Monitoring
- Panel Event Signal Silence Capability
- Color Coded Header Bar
- Touch points for Acknowledge (ACK), Silence, and Reset
- Adjustable back-light intensity
- User defined informational text
- Clickable Menu bread crumbs
- Audio and visual feedback on touch point
- Reminder for Fire, Supervisory, CO, and Trouble
- Trouble Relay
- Event LED to indicate an off normal status on the NCD
- AC power LED to indicate primary power status
- Piezo to indicate unacknowledged events
- Tamper and Trouble inputs
- 3 USB Ports
- Configurable using VeriFire Tools.
- Lamp Test locally on the NCD

- AC Fail Delay
- Drill button activates silenceable outputs
- Expandable logic zones: 250 at base functionality up to 2000, in multiples of 250 through one time license
- Custom Action buttons : 8 at base functionality up to 32, in multiples of 8 through one time license

1.9 NCD DISPLAY

The NCD has as high definition 10 inch touch screen to display system and panel events. A touch point for menu access, a Header Bar which shows color coded event status, and touch points for acknowledge, signal silence, and reset.

1.9.0.1. Menu Main Window Button

The Main Menu window button is always present and located on the top left of the screen. Tapping on this touch point will take the user to the menu list from the main window or back to the main window from any menu screen.

1.9.0.2. User Login Button

The User Login Button is always present and located on the top left of the screen. Tapping on this touch point will bring the user to the login screen for individual users. For more information on User Login, refer to "3.3.11. User Login" on page 31.

1.9.0.3. Header Bar

The "Header Bar" is always present and located along the top of the screen. It displays all active events, system normal, and the "Acknowledge", "Silence" and "Reset" touch points. The date and time are also displayed in the Header Bar. It provides system status as well as the highest priority event.

1.9.0.4. Instructional Text Area

The Instructional Text Area is used to provide user instruction in an off-normal condition. The instructional text can be enabled and disabled, and is fully configurable through VeriFire Tools.

1.9.0.5. Alert Bar

The "Alert Bar" is always present and located along the side of the screen. The Alert Bar event categories can be configured though VeriFire Tools . It shows color coded events, such as "Fire Alarm", "CO Alarm", "Supervisory" activation, "Trouble" activation, "Drill" activation" along with event counts and whether the outputs have been silenced.

1.9.0.6. Events List

The “Events List” (Main Display Area) shows all events and their status. It indicates if events have been acknowledged and is color coded as well as scrollable.

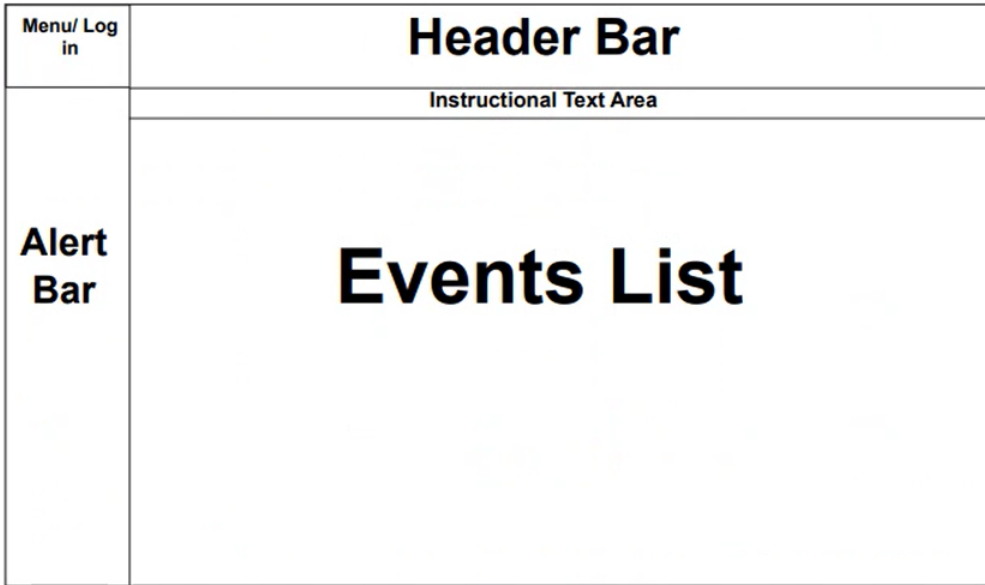

Figure 1.1 Display Regions

Display Conditioning

Every 30 minutes the display will enter Display Conditioning mode. During Display Conditioning the display will transition through various screens including a completely blank screen. This process takes about seven seconds. It is done to prevent image persistence, and keeps information clear and undistorted. Any display interaction will abort Display Conditioning mode. The Display Conditioning Mode does not activate when there are alarms or pre-alarms in the system.

1.10 LICENSING

The NCD has 250 logic zones and 8 custom action button out of the box. The functionality can be expanded by applying the following optional licenses.

Title	Licence	Description
LogicZone Expansion	Logic Zones Yes ¹	Configuring or programming a zone that exceeds the limit set by the license(s) will generate a trouble condition. Multiple licenses can be activated for the same panel, each license will expand the logic zone limit
Custom Actions	Yes	Initial 8 Custom Action touch points require NO license. Each set of 8 Custom Actions touch points following the initial 8 will require a license. The NCD and N16 only supports up to 32 Custom Action touch points.

Table 1.3: Licensing Requirements

1.11 TECHNICAL SPECIFICATIONS

1.11.1. POWER INPUT:

24 VDC.

1.11.2. USB PORTS:

Supports USB version 2.0. USB A and USB Micro are located on the core board. USB C is located on the front of the NCD Display.

1.11.3. TOUCH SCREEN DISPLAY:

10 inch High Definition Touch Screen Display.

1.11.4. CURRENT DRAW:

360mA in Standby. 380mA in Alarm.

1.11.5. TAMPER AND TROUBLE INPUT:

Tamper and Trouble inputs.

1.11.6. TROUBLE RELAY:

30 VDC 2A.

¹Logic Zones, up to 250 zones, no license required. Additional blocks of 250 zones will require a license for each block. Maximum of up to 2000 zones.

SECTION 2: INSTALLATION

2.1 PREPARING FOR INSTALLATION

Choose a location for the NCD that is clean, dry, and vibration-free with moderate temperature. The area should be readily accessible with sufficient room to easily install and maintain it. There should be sufficient space for cabinet door(s) to open completely.

Carefully unpack the system and inspect for shipping damage. Count the number of conductors needed for all devices and find the appropriate knockouts.

Before installing the NCD, read the following:

- Review the installation precautions at the front of this manual.
- Installers should be familiar with the standards and codes specified in "Section 1: About this Manual" on page 1.
- All wiring must comply with the National and Local codes for fire alarm systems.
- Do not draw wiring into the bottom 9 inches (22.86 cm) of the cabinet except when using a separate battery cabinet; this space is for internal battery installation.
- Wiring methods used shall be in accordance with Standard for Installation and Classification of Burglar and Holdup Alarm Systems, UL 681
- Review installation instructions in "2.1.1. Installation Checklist" below.



WARNING!

- Risk of equipment damage.
Make sure to install system components in the sequence listed below. Failure to do so can damage the control panel and other system components.
- Wear a static discharge strap on wrist to prevent equipment damage.
- Adjusting the screen brightness greater than 75% will reduce the life of the display.

2.1.1. INSTALLATION CHECKLIST

The checklist that follows contains references to information included in other manuals; see "1.4 Related Documentation" on page 2 for document part numbers.

Task	Refer to:
Mount the cabinet backbox to the wall.	"" below
Attach NCD to dress panel.	Dress Plate Mounting
Attach option boards (e.g. network communications modules and other devices of the same size) to chassis and dress plates.	Refer to the Installation document for the specific device and dress plates.
Attach chassis in assembled dress plate to cabinet.	"" below
Wire Relays	" Figure 2-1:Board Layout and Wiring Requirements" on page 21
Digital Voice components.	<i>Digital Voice Control Manual</i> , etc.
Network devices.	Noti•Fire•Net Version 5.0 & Higher Manual, or High-Speed Noti•Fire•Net Manual and/or Installation document for specific device(s).
Main power supply.	Main Power Supply Manual BB-100/200 Cabinet Installation Instructions.
Install main power supply and batteries. Run cables to main and optional power supplies, DC power outputs, relays, etc.	Applicable system and power supply manuals.
<div style="border: 2px solid red; padding: 10px; display: inline-block;">  WARNING! Risk of equipment damage. Do not activate power at this time. Do not connect batteries. </div>	
Check that all mounting holes are secured to insure a proper Earth Ground connection.	
Connect wire shielding to Earth Ground.	
Apply AC power to the power supply or the control panel. Do NOT connect batteries until AC power is checked (see next step).	
Check AC power.	Power Supply manual.
Connect the batteries using interconnect cable as described in power supply manual.	
Install the dress panels, doors and covers.	CAB-3/CAB-4 Series Cabinet Installation Document.
Program the NCD.	"Section 3: Programming" on page 26
Field test the system.	

Table 2.1: Installation Checklist



Typical NFN Configurations

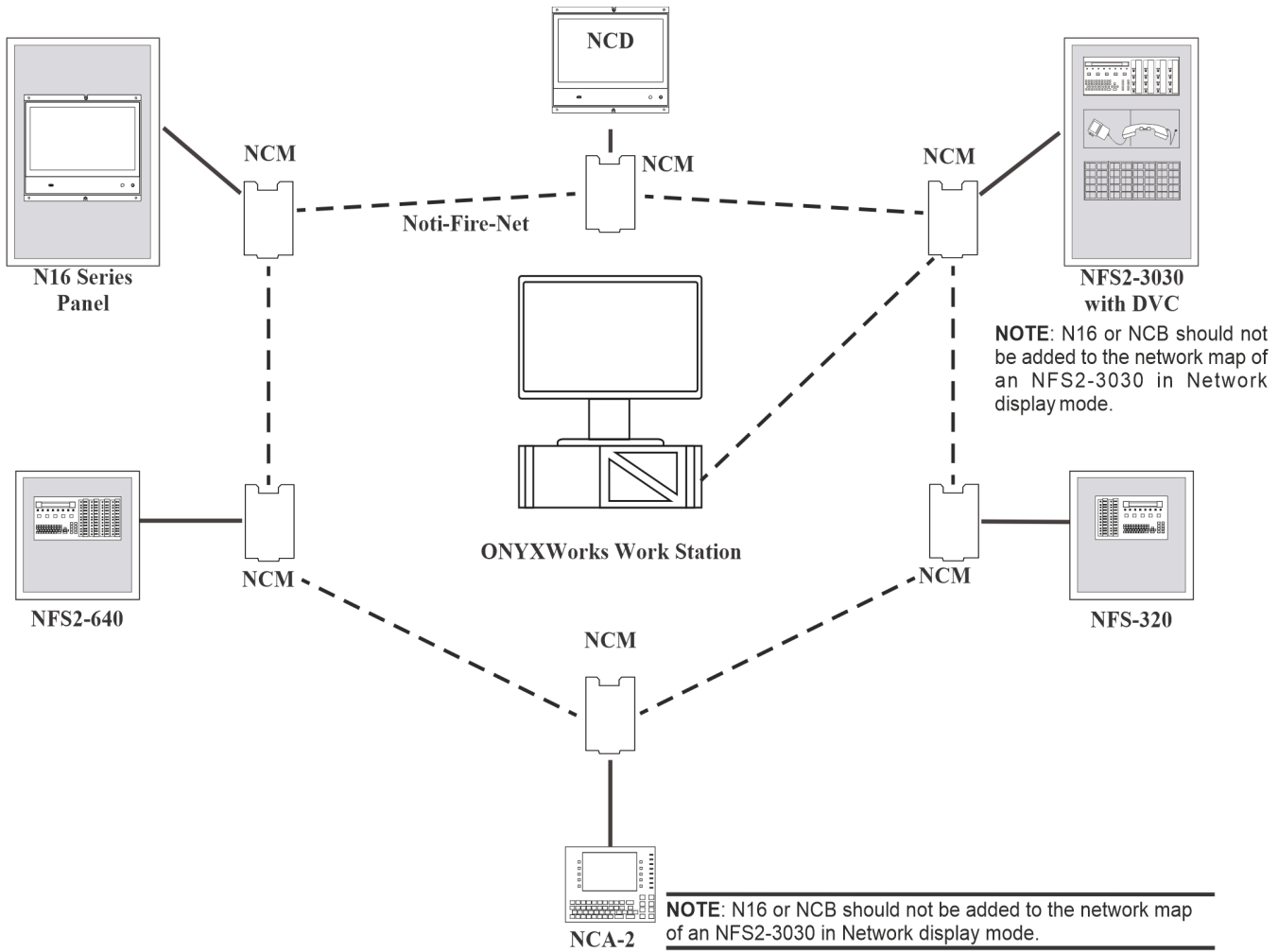
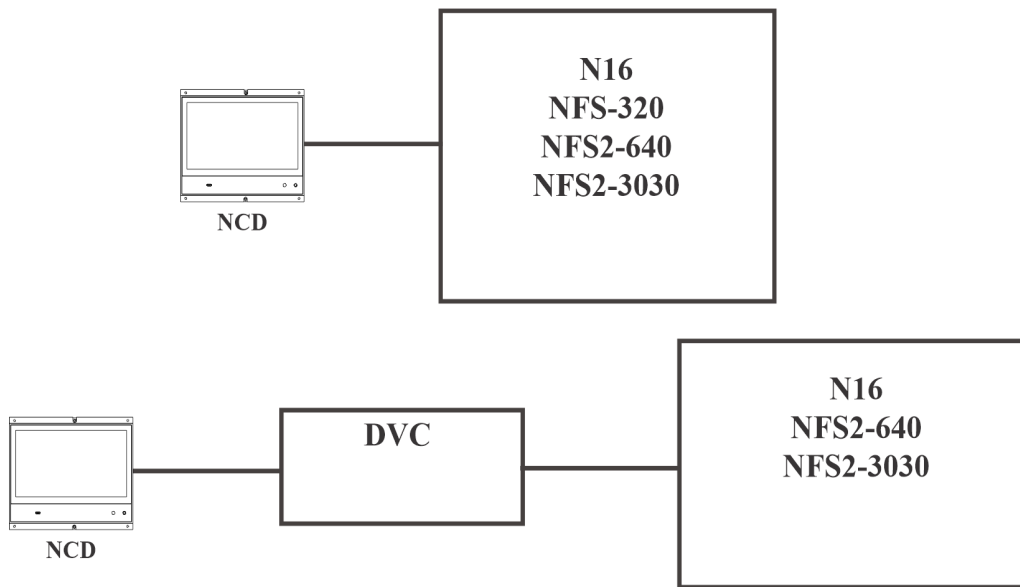

Typical Configurations for Systems Using the NCD as a Display

NOTE: In this diagram, the term: "NCM" includes standard and high-speed network communication modules. "Noti-Fire-Net" includes standard and high-speed network versions.

2.2 CAB-4 AND CAB-5 SERIES CABINETS

This section provides instructions for mounting the CAB-4 Series backbox to a wall. Follow these guidelines when mounting the backbox:

Locate the cabinet backbox on a surface that is in a clean, dry, vibration-free area. The top should be located so that all operational buttons, switches, displays, etc. are easily accessible and/or viewable to the operator - usually no more than 66 inches (1.7m.) above the floor. Allow sufficient clearance around the cabinet for the door to swing freely, and for easy installation and maintenance of equipment.

- Use the four holes in the back surface of the backbox to provide secure mounting (See " Figure 2-1:CAB-4 Backbox-Mounting Holes and chassis-Mounting Studs" below).
- Mount the backbox on a surface that is in a clean, dry, vibration-free area.
- Mark and pre-drill holes for the top two keyhole mounting bolts.
- Select and punch open the appropriate knock-outs.
- Using the keyholes, mount the backbox over the two screws.
- Mark the location for the two lower holes, remove the backbox and drill the mounting holes.
- Mount the backbox over the top two screws, then install the remaining fasteners. Tighten all fasteners securely.
- Feed wires through appropriate knockouts.
- Install the NCD and other components according to this section, before installing hinges and door (see *CAB-3/CAB-4 Series Cabinet Installation Document*).

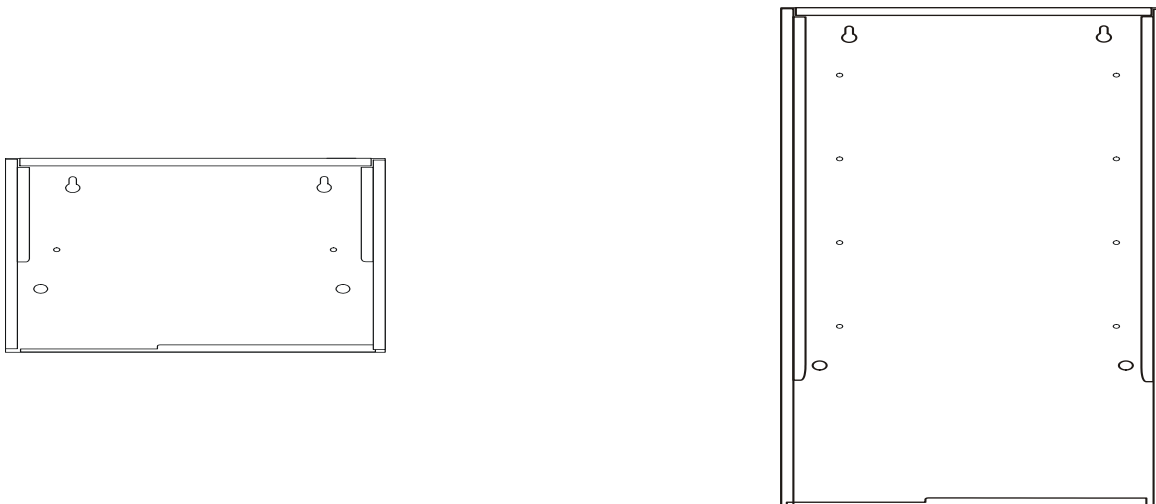
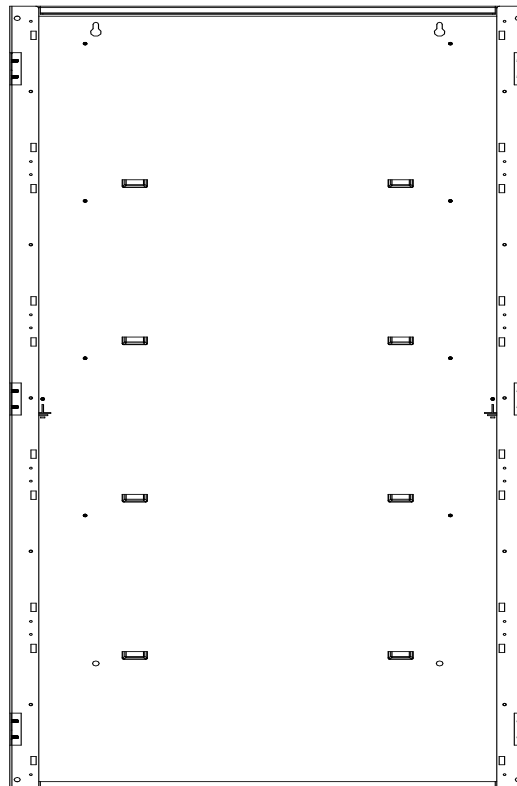
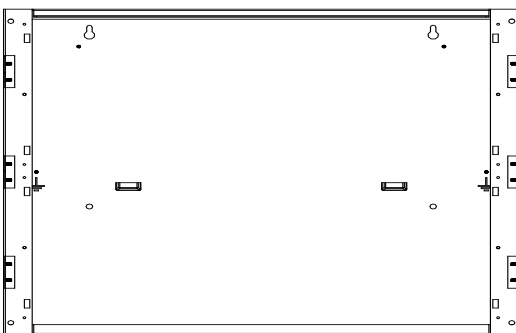

Figure 2-1:CAB-4 Backbox-Mounting Holes and chassis-Mounting Studs

This section provides instructions for mounting the CAB-5 Series backbox to a wall. Follow these guidelines when mounting the backbox:

Locate the cabinet backbox on a surface that is in a clean, dry, vibration-free area. The top should be located so that all operational buttons, switches, displays, etc. are easily accessible and/or viewable to the operator - usually no more than 66 inches (1.7m.) above the floor. Allow sufficient clearance around the cabinet for the door to swing freely, and for easy installation and maintenance of equipment.

- Use the four holes in the back surface of the backbox to provide secure mounting (See " Figure 2-1:CAB-4 Backbox-Mounting Holes and chassis-Mounting Studs" on the previous page).
- Mount the backbox on a surface that is in a clean, dry, vibration-free area.
- Mark and pre-drill holes for the top two keyhole mounting bolts.
- Select and punch open the appropriate knock-outs.
- Using the keyholes, mount the backbox over the two screws.
- Mark the location for the two lower holes, remove the backbox and drill the mounting holes.
- Mount the backbox over the top two screws, then install the remaining fasteners. Tighten all fasteners securely.
- Feed wires through appropriate knockouts. Install CPU-N16LD/ND and other components according to this section, before installing hinges and door





WARNING! Risk of equipment damage.

Use specified stand-off mounting locations only. Do not use corner holds for installation purposes. It is critical that all mounting holes of the fire alarm control panel are secured with a screw or standoff to insure continuity to ground.

2.3 INSTALLING THE NCD ON ONYX SERIES PANELS MOUNTING THE NCD ON THE NFS2-3030



NOTE: The Network Control display (NCD) must be installed in position one on the LEFT side of the CHS-MS for NFS2-3030 mounting.

The NFS2-3030 CPU mounts in the CHS-M3 chassis located in the top row of the cabinet. The CPU will occupy the left half of the chassis.

When using the NCD as a primary display, the NFS2-3030 CPU will need to be remounted with shorter 1/4 inch standoffs (PN 42138) included with the NCD.

The NCD can be directly connected to the NUP port of the CPU2-3030.

When using the NCD as an alternate display on a standard Noti•Fire•Net, the panel becomes standalone and is not networkable, since there is only one NUP port available on the NCM. If the panel is on a High-Speed Noti•Fire•Net, the panel can be networked using the second NUP available on the HS-NCM.

The NFS2-3030 CPU should be installed according to "" below to accommodate the NCD. If this is a retrofit, you will need to remove the LCD Display, Keypad, and Header Pins. The CPU will be reinstalled in slot 3.

To install the NFS2-3030 CPU do the following:

- Attach three standoffs (PN 42138) to chassis as shown in
- Slide circuit-board tabs into slot 3 on the chassis.
- Place the board over the stand-offs so that mounting holes line up with those on the chassis. Secure all stand-offs with screws provided.
- The NCD will be mounted to the dress plate, see "2.4 Dress Plate Mounting" on page 17 for more information.



CAUTION: equipment ground

CPU standoffs at Positions 1 and 2:
0.25 inch (6.35 mm) for use with CPU2-3030

Chassis-mounting slots

- CPU2-3030
(without keypad/display)
Slot 3
- Do Not Use
Slot 2
- Do Not Use
Slot 1

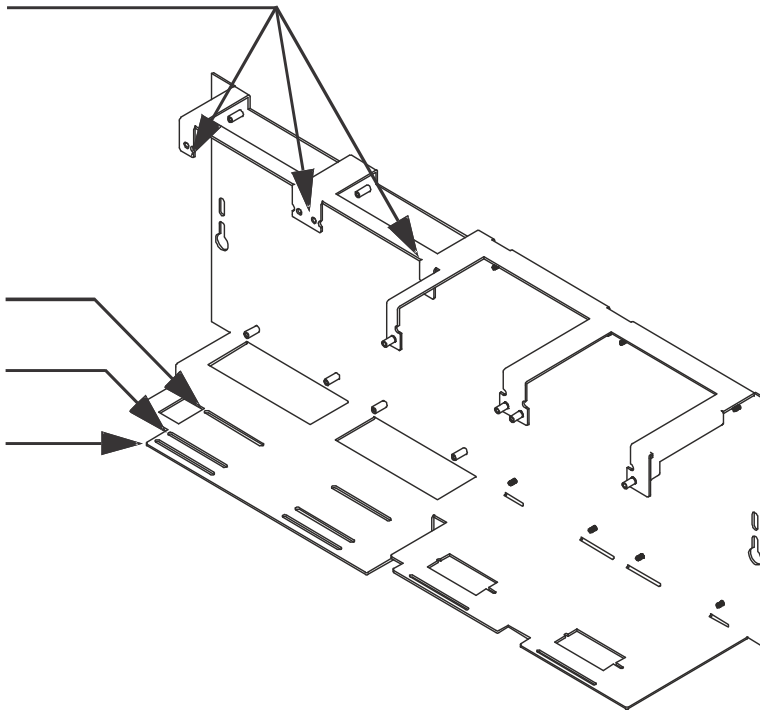

CAUTION: Equipment Ground

It is critical that all mounting holes of the NETWORK control display (NCD) as well as the NFS2-3030 CPU are secured with grounding screws and standoffs to insure continuity of Earth Ground.

2.3.1. USING THE NCD AS PRIMARY DISPLAY ON THE NFS2-640 AND NFS-320SYS

The NCD can be directly connected to the NUP port of the CPU2-640 or the NFS-320SYS

The NFS2-640/E and NFS-320SYS can be set up to use the NCD as the primary display.

When the NCD is used as the primary display, the KDM-R2 needs to be removed.

When using the NCD as an alternate display for the NFS2-640 or NFS-320SYS on a standard Noti•Fire•Net, the panel becomes standalone and is not networkable, since there is only one NUP port available on the NCM. If the panel is on a High-Speed Noti•Fire•Net, the panel can be networked using the second NUP available on the HS-NCM.

The NCD can only be mounted on the left side of the DP-GDIS1 dress plate, Refer to "2.4 Dress Plate Mounting" on page 17 for NCD mounting. If using the DP-DIS2 the NCD maybe mounted in tiers 2, 3, 4 of the CAB4 Minimum firmware required for CPU2-640 / NFS-320SYS is v29.

**NOTE:**

- If the NFS2-640/E, or NFS-320SYS and NCD are being used as a stand-alone pair, each device must be programmed using VeriFire Tools. Connect the VeriFire ToolsPC to NFS2-640 or NFS-320SYS using USB B Port J3 and program as described in VeriFire Tools on-line help.
- For older PCs without USB connectors, NFS2-640/E, or NFS-320SYS and NCD must be temporarily disconnected and separately programmed, because VeriFire Tools also uses the network/service port. Follow VeriFire Tools instructions for off-line programming mode.

2.3.2. NFS-320/SYS AND NFS2-640 MOUNTING

The Network Control Display (NCD) can only be installed in the LEFT mounting position on the dress plate DP-GDIS1

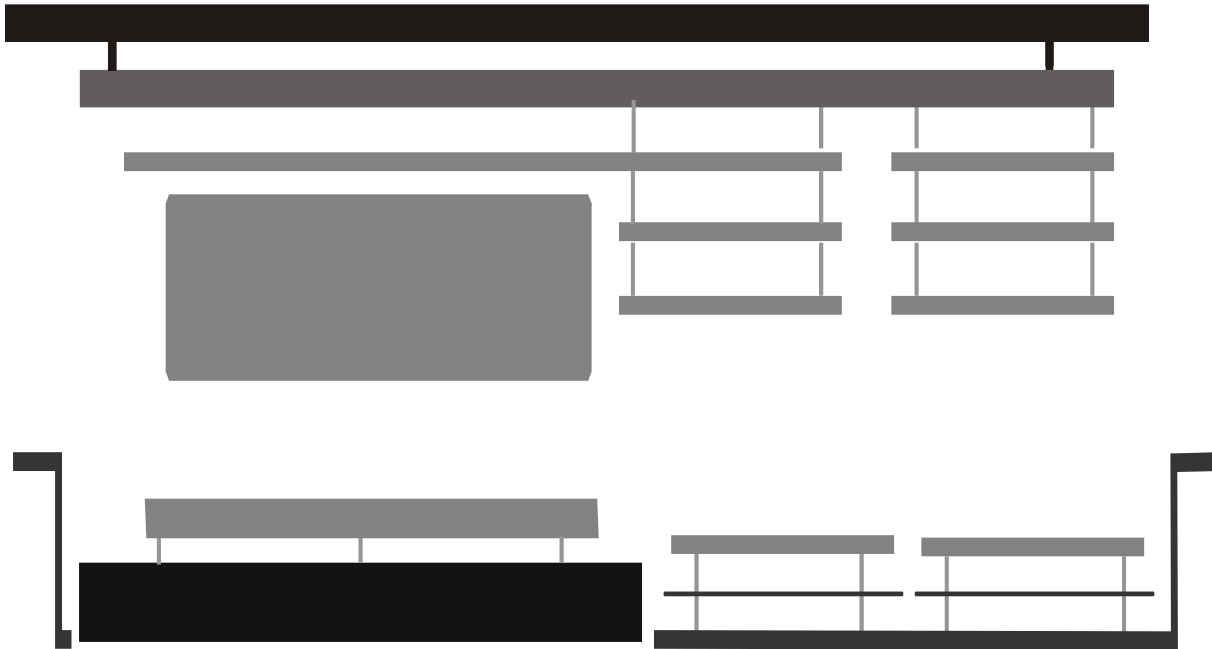

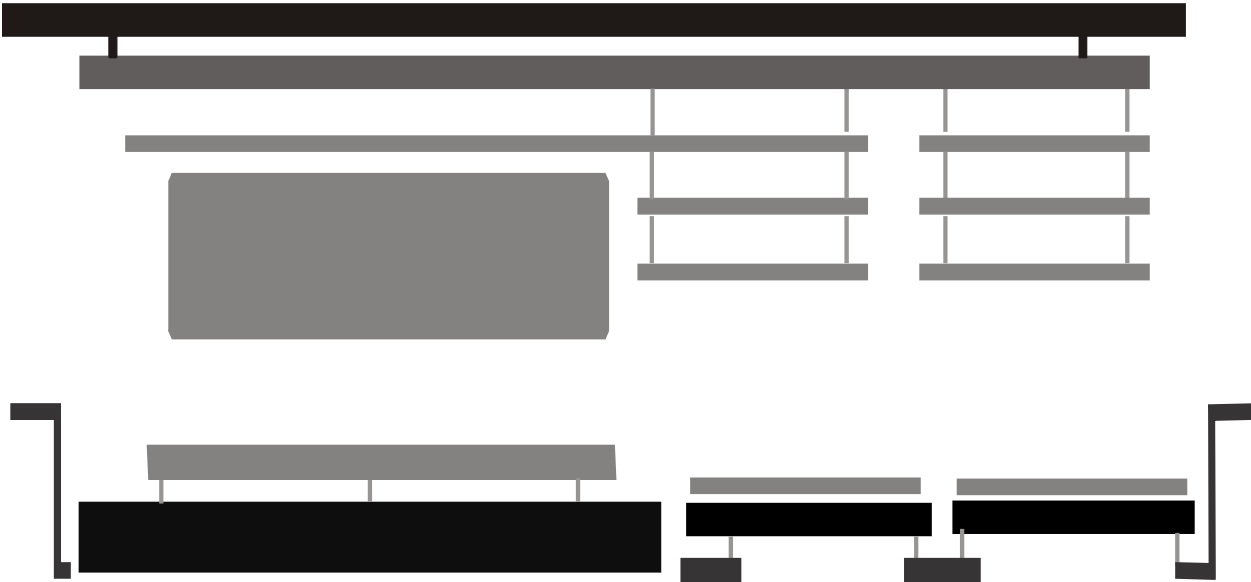

2.4 DRESS PLATE MOUNTING

Refer to " Figure 2-1:Dress Plate Mounting" on the next page for information on mounting the NCD to the DP-GDIS1 (for row A of the CAB-4 Series Cabinet) and DP-T2A (for CAB-5 Series Cabinet) or DP-GDIS2 (for rows B-D of the CAB-4 Series Cabinet).

- Locate the four mounting studs on the dress plate.
- Locate the two ground screw standoffs on the dress plate.
- Line up mounting holes on the NCD with the mounting studs on the dress plate with the screen facing out.
- Secure the NCD to the dress plate using the four #4-40 nuts to fasten the NCD to the dress plate.
- Install Ground Screws on the dress plate using two #6-32 screws.



NOTE: It is important to secure ground screws on both the Core (top) and DIM (bottom) board for proper operation.

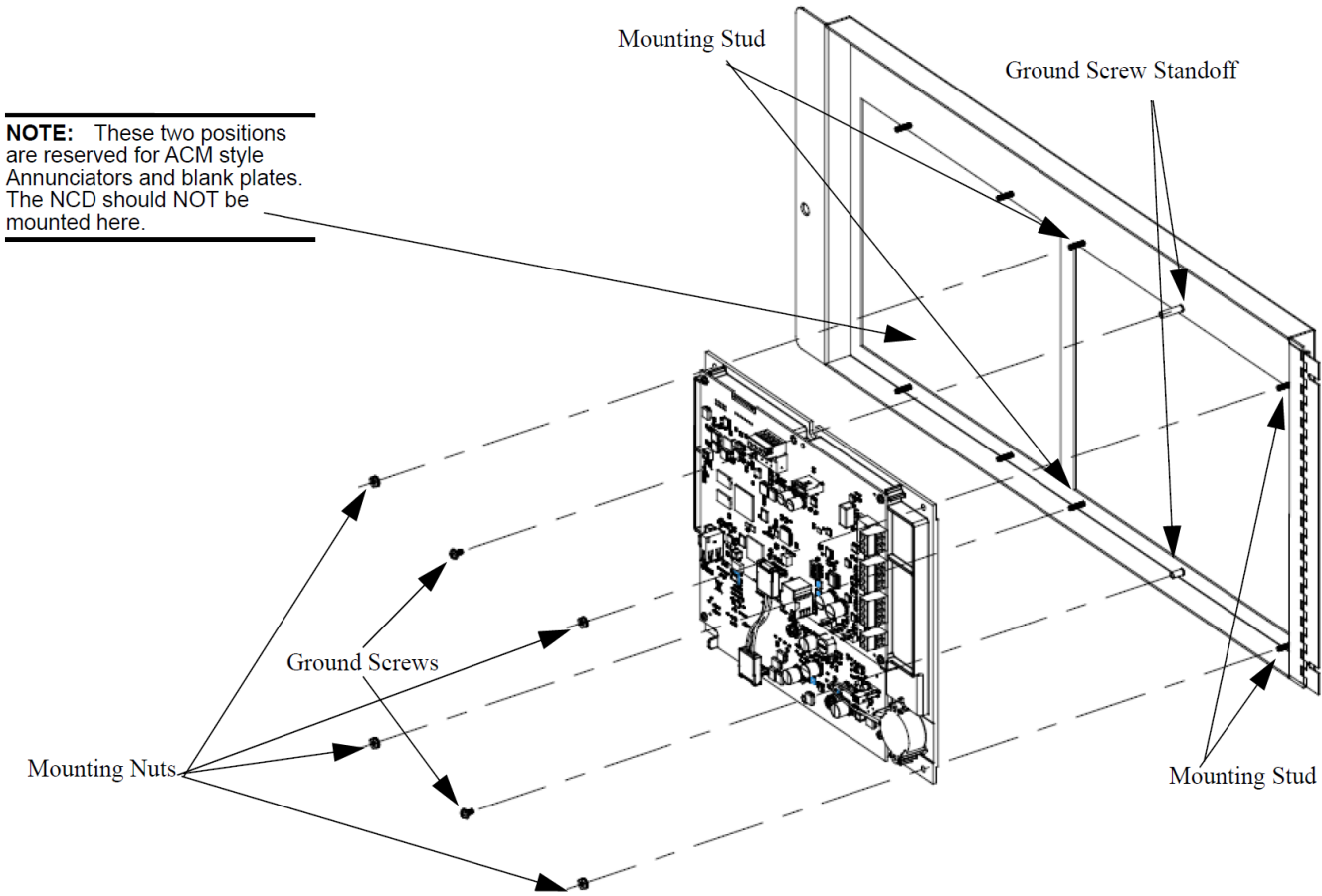



Figure 2-1: Dress Plate Mounting

2.5 WIRING AIO BUS DEVICES TO THE NCD

 NOTE: AIO Bus capabilities require a Core-2PCA (marked on the PCB) or a CPU-N16-RB replacement board to function.

Wire the AIO circuit as shown in "" on the next page. All power must be disconnected when connecting the annunciator. These requirements must be followed:

 NOTE: The RLD can only be wired to the Main AIO Bus and can only be a router on the AIO.

- AIO wiring to the main bus of the NCD can be wired class A or class B.
- AIO wiring to the local bus of the NCD can be wired class B only.
- The AIO circuit cannot be T-Tapped; it must be wired in a continuous fashion to function properly.

- There is a maximum of 6,000 feet at 16 AWG between the panel and the last annunciator on the AIO circuit (subject to the system's power restrictions). In a class B configuration there is a maximum of 6,000 feet at 16 AWG between the panel and the last annunciator (subject to the system's power restrictions).
- In a class A configuration there is a maximum overall distance of 200 feet at 16 AWG between the panel endpoints (A to B) on the external AIO circuit with connector TB5 (subject to the system's power restrictions).
- The wiring size must be a 12 AWG to 18 AWG twisted shielded pair cable having a characteristic impedance of 120 ohms, +/- 20%.
- Each AIO circuit is range rated for 18 VDC to 30 VDC with a max current draw of 93mA.
- Do not run cable adjacent to, or in the same conduit as, 120 volts AC service, "noisy" electrical circuits that are powering mechanical bells or horns, audio circuits above 25 VRMS, motor control circuits, or SCR power circuits.
- If annunciators are to be mounted in a separate cabinet or powered by a remote power supply, see "A common reference connection must be made between multiple power supplies for the AIO circuit to function properly." below.

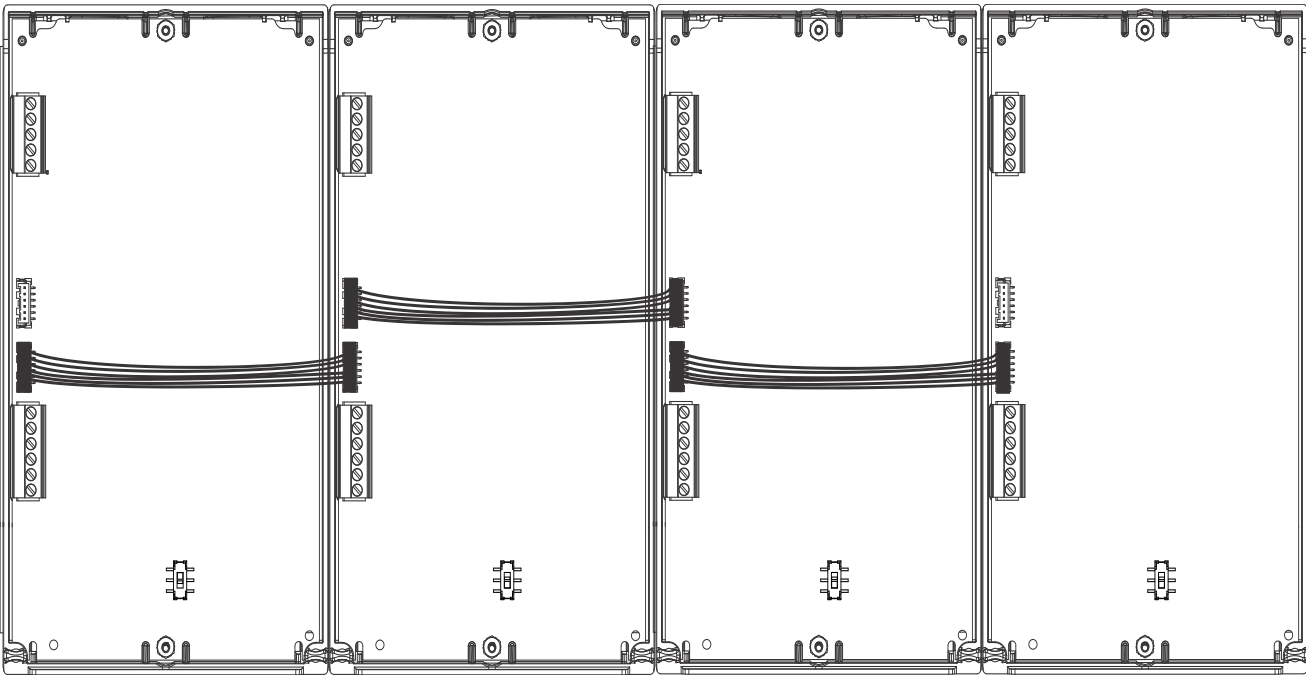

A common reference connection must be made between multiple power supplies for the AIO circuit to function properly.

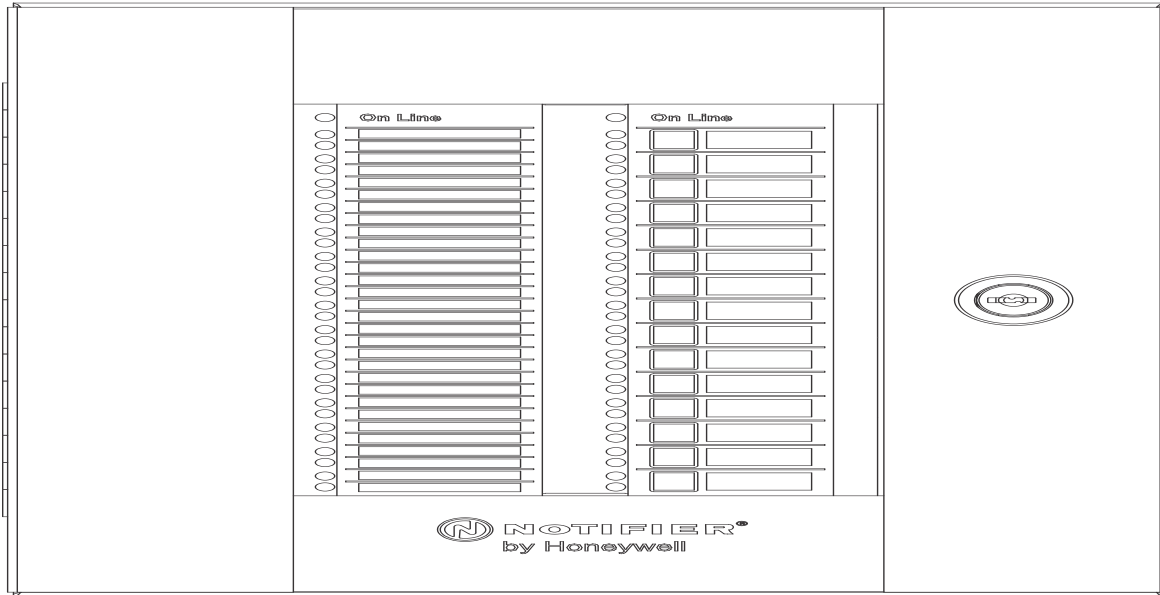

2.5.1. TERMINATION RESISTORS

The end-of-line termination resistor must be enabled on S3 on the last device on the Main AIO Circuit. The end-of-line termination resistor must be enabled at S39 on the first and last devices on the Local AIO circuit. All other annunciators should have these switches set to disable.

If the TM-8 is the last annunciator in the wire run on an AIO bus, the termination resistance switch on the TM-8 circuit board should be set to “IN”. They should be directed to the TM-8 Installation PID for details.

There are two AIO busses in the system, “MAIN” & “LOCAL”. Every annunciator on the MAIN AIO bus and LOCAL AIO bus must have a unique address setting. Every annunciator on the MAIN AIO bus must be set as a “ROUTER” using another switch on the board. Every annunciator on the LOCAL AIO bus must be set as a “PERIPHERAL” using that switch. These roles allow MAIN and LOCAL address settings to be independent of each other.

2.5.2. END-OF-LINE RESISTORS ON THE ACM-30

The end-of-line termination resistor must be enabled at S3 on the last device on the Main AIO circuit. The end-of-line termination resistor must be enabled at S39 on the first and last devices on the Local AIO circuit. All other annunciators should have these switches set to disable.

2.5.3. ADDRESSING THE ACM-30

Set the address with rotary switches SW1 and SW2 on the back of the annunciator. Turn the arrow with a small flat-head until it points to the correct digit. S1 selects the Tens digit of the address. S2 selects the Ones digit of the address. These addresses must match what is entered into VeriFire Tools programming.

The system supports up to 10 router devices connected to the control panel using up to 10 unique addresses. Each router can have up to 15 peripheral devices connected to it. A total of 80 devices are allowed on the AIO circuit, including routers and peripherals.

Refer to the *ACM-30 Manual LS10238-000GE-E* for more information.

2.5.4. END-OF-LINE RESISTORS ON THE RLD

The end-of-line termination resistor must be enabled through the on screen programming menu of the RLD. Refer to the *RLD User Manual LS10310-000NF-E* for more information.

2.5.5. ADDRESSING THE RLD

The RLD address is set through the on screen programming menu of the RLD and the setting must match what is programmed in VeriFire Tools. Note that the RLD can only be configured as a router. Refer to the *RLD User Manual LS10310-000NF-E* for more information.

2.6 BOARD LAYOUT AND WIRING REQUIREMENTS

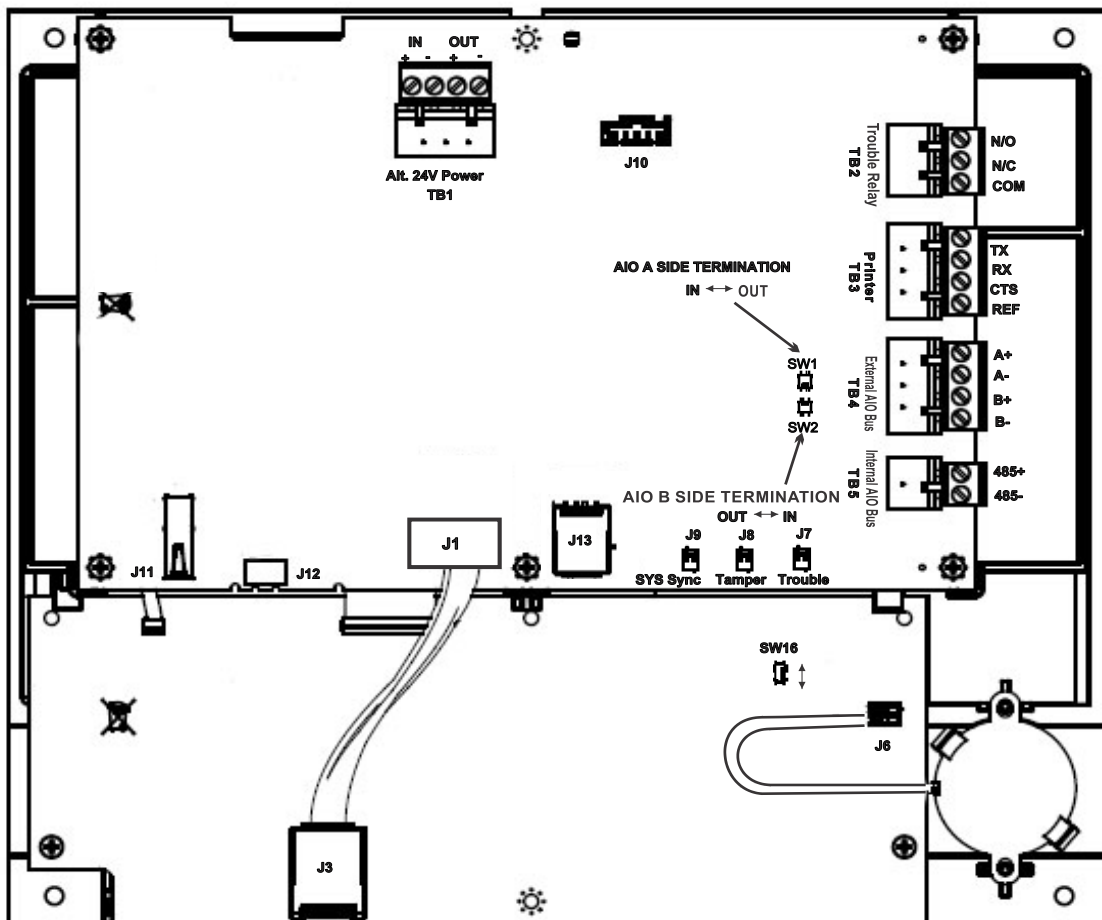

Figure 2-1: Board Layout and Wiring Requirements

**WARNING! RISK OF EQUIPMENT DAMAGE**

Do not connect or disconnect the oculink cable between the core and Dim boards (upper and lower boards) while power is applied to prevent system damage.

Designator	Description	Specification
TB1	Alt 24 V Power	Primary power input for the NCD 18-30 VDC
TB2	Trouble Relay	30 VDC 2A, 0.35 PF Non-power-limited Form C dry contact
TB3*	Printer Connection (for supplemental use only)	Power-limited (Class 2) Supervision of end to end communication Isolated printer connection (left side) Equipment must be located in the same room within 20 feet of the panel with cables in conduit
TB4	Main AIO Bus	Characteristic impedance: 120 ohms Supervised Power-limited (Class 2) A maximum of 80 annunciator devices can be connected to the node between the internal external bus. Up to 10 annunciators can be configured as routers, each supporting 15 additional annunciators Must be within 20ft of panel Must be in same room as panel Cable must be in conduit
TB5	AIO Bus	Characteristic impedance: 120 ohms Supervised return Power-limited (Class 2) A maximum of 80 annunciator devices can be connected to the node between the internal external bus. Up to 10 annunciators can be configured as routers, each supporting 15 additional annunciators. <ul style="list-style-type: none"> ▪ Class B wiring maximum of 6,000 feet at 16 AWG between the panel and the last annunciator (subject to the system's power restrictions). ▪ Class A wiring maximum of 200 feet at 16 AWG between the panel endpoints (A to B) (subject to the system's power restrictions).
J1	OCuLink Connection	To display (DIS-10-RD)
J7	Trouble Input	Dry contact
J8	Tamper Input	Dry contact
J9	Future Use	Future use

Designator	Description	Specification
J10	Network Service Connection (NUP)	Power-limited (Class 2) Supervised Must be in cabinet located in the same room within 20 feet of the panel with cables in conduit
J11	USB A	N/A
J12	USB B Micro	N/A
J13	Future Use	Future use

**NOTE:**

- AIO Bus capabilities and the printer connection require a Core-2PCA (marked on the PCB) or a CPU-NCD-RB replacement board to function.
- 24 VDC is required to power the NCD (TB1 located on the NCD).

2.6.1. GROUND SCREW LOCATIONS

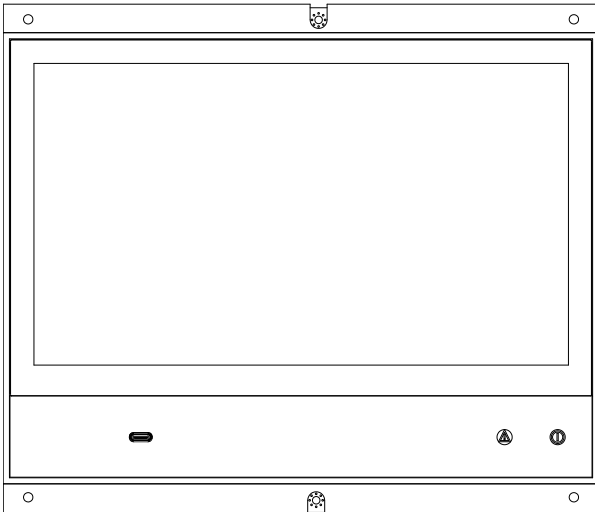

Ground screws are located at the center top and bottom center on the front of the NCD. It is important to secure each screw to maintain proper grounding. See Figure 2.10

2.6.2. EVEN INDICATOR LOCATIONS

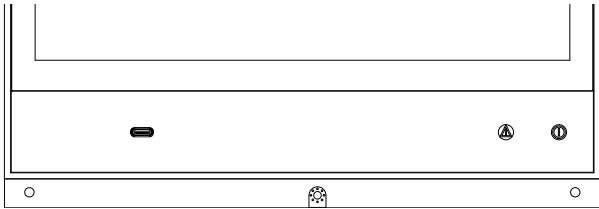

There are two LED indicators located on the bottom right of the NCD front panel. A power LED to indicate if A/C is present, and an off normal LED for any off normal condition. See Figure 2.11

2.6.3. PIEZO ENABLE/DISABLE

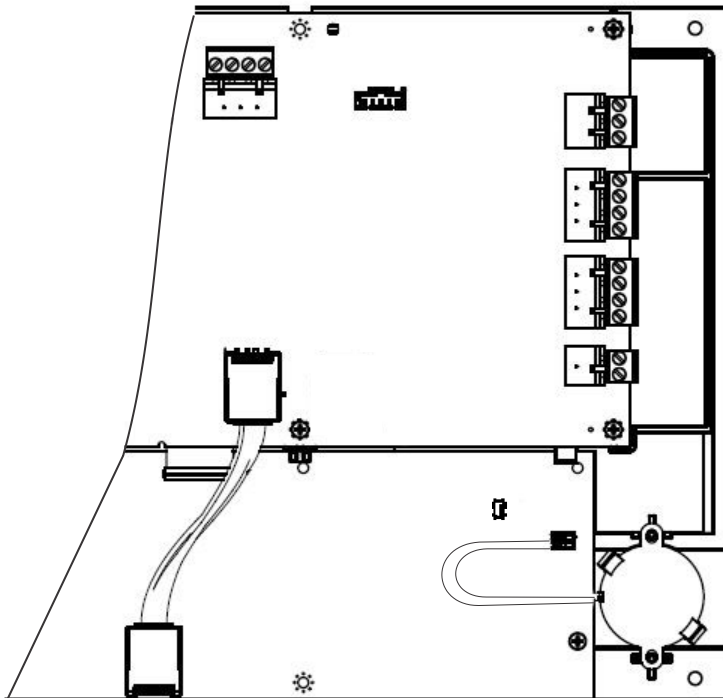

CAUTION: Piezo enable/disable
For technician and service use only.

To enable the Piezo, position SW16 in the UP position.

To disable the Piezo, position SW16 in the DOWN position.

When the Piezo is disabled the NCD will display a trouble condition until it is re-enabled. See Figure 2.12

SECTION 3: PROGRAMMING

This section describes the programming options for the NCD

3.1 USB PORT C

There is an available USB port located on the front panel of the NCD, see "3.1 USB Port C" above. This USB port can be used to conveniently connect to the VeriFire Tools PC.

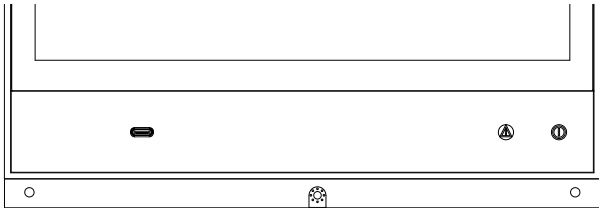

3.2 PASSWORD REQUIREMENTS

When power is first applied, the NCD will prompt the user to change the password. A trouble message stating CHANGE THE PASSWORD will be displayed. The master password can only be set through the NCD display. Default master or service tool password is 00000000. Default passwords will generate persistent troubles in the panel.

The service tool password is used to authenticate downloads to the panel. Service tool password may be reset or changed at the panel once you are logged in as a master

Verifier tools can be used to create a database of user accounts wherein you may add/remove/change users and user passwords and access restrictions for all 50 users including the master. User accounts can be downloaded to the panel with service tool authentication

The password guidelines are as follows: Passwords must be 8 to 16 characters, which can be a combination of alpha-numeric upper and lower case characters and numbers. The password does not have a minimum of character types and is case sensitive



NOTE: For firmware version 5.0 or higher, a USB Drive is required for password recovery

3.3 MENU NAVIGATION

The menu touch point is always present and located in the upper left hand corner of the screen. Tap this touch point to bring up the menu options for settings, programming, point information, test/diagnostics and custom. The menu screen navigation is not accessible when there are current unacknowledged active events. An incoming alarm will automatically exit the menu screen to the Events List.

3.3.1. SETTINGS

Tap the settings touch point to access the Settings menu. This menu provides access to display settings, brightness, clean mode, version information, user accounts, system settings, and system update. Refer to section "3.3.8. Settings" on the next page

3.3.2. PROGRAMMING

Tap the programming touch point to enter the Programming menu. This menu provides access to network programming. Refer to "3.3.9. Programming" on the next page.

X	⌂	System Normal	✓ Ack	🔇 Silence	↶ Reset	Tue 01/20/20 02:38:06PM Master
🔥 FIRE ALARM	Menu					
🌊 CO ALARM	⚙️ SETTINGS	Date, Time, Display, Version Information, User Accounts, Clear Verification Counts, Service Mode, Licensing				>
📡 SUPERVISORY	⚙️ PROGRAMMING	Network Mapping, Node Address				>
⚠️ TROUBLE	📄 POINT INFORMATION	Control On/Off, Disable/Enable, Point History				>
🚫 DISABLE	🔧 TEST/DIAGNOSTICS	Circuit Board Temperature, CPU Temperature, Statistics, Lamp Test, Panel History				>
*** OTHER	🔧 CUSTOM	Custom Actions				>
🔇 SIGNALS SILENCED						

3.3.3. CUSTOM ACTIONS

Only programmable through VeriFire Tools. Refer to "3.5 Custom Actions" on page 37 as well as VeriFire Tools.

3.3.4. POINT INFORMATION

Allows the user to enable and disable system points, force on/off points, read status, and view point history.

3.3.5. DRILL

The Drill button can be customized to the alert bar. It is programmable through VeriFire Tools. Tap this touch point and hold for two seconds to activate all silenceable fire output circuits.

3.3.6. DISABLE POINTS/FUNCTIONS

3.3.7. TEST/DIAGNOSTICS

Tap the test/diagnostics touch point to enter the Test/Diagnostics menu. This menu provides access to Lamp Test, temperature values, diagnostic data, and history view.

3.3.8. SETTINGS

Tapping the settings touch point on the Menu screen will display the Settings options on the NCD.

Display

Tap on the display touch point to adjust brightness or enter clean mode. Refer "3.3.8. Settings" above

About (option under Settings)

Version information

System Update

Tap the touch point System Update to access application, kernel, full system, and wallpaper update capabilities. To update the application tap the touch point update application. To update the kernel tap the touch point update kernel. To update the full system tap the touch point update full system. To update the wallpaper tap the touch point update wallpaper. For all updates the virtual keyboard will appear once the selected update is tapped on, tap in the file name to update and then tap the touch point perform update to complete the update. Updates can be done from a file on a USB drive connected to the panel.

User Accounts

Manages users/passwords

Panel

Provides means to clear detector verification counts, enter/exit service mode, and set date/time.

Licensing (option under Settings)

Displays licenses installed in panel.

3.3.9. PROGRAMMING

Tapping the programming touch point on the menu screen will display the programming options menu.

Network

Tap the network touch point to display the Network options for the NCD.

☰	🔍	System Normal	✓ Ack	🔇 Silence	↶ Reset	Thu 2/22/18 1:38:06PM
🔥 FIRE ALARM	Menu - > Programming					
🌊 CO ALARM	Programming					
📶 SUPERVISORY	NETWORK					
⚠️ TROUBLE						
🚫 DISABLE						
⋮ OTHER						
SIGNALS SILENCED						

☰	🔍	System Normal	✓ Ack	🔇 Silence	↶ Reset	Thu 2/22/18 1:38:06PM
🔥 FIRE ALARM	Menu - > Programming - > Network					
🌊 CO ALARM	< Network					
📶 SUPERVISORY	<p>Node Number</p> <p>The network node number for this panel. When the panel is not connected to a network, the network node number is zero. 50</p>					
⚠️ TROUBLE	<p>Network Mapping</p> <p>Tap the MAPPING button to view the network nodes that this panel is monitoring along with the type(s) of mapping specific to each node.</p> <div style="text-align: right; border: 1px solid black; padding: 5px; display: inline-block;">MAPPING</div>					
🚫 DISABLE						
⋮ OTHER						
SIGNALS SILENCED						

Node Number

Displays the network node number for the NCD. If there is no network, the node number will be zero.

Node Label

Displays the programmed label of the NCD.

Network Mapping

Displays the network nodes the system is monitoring. See "3.3.10. " on the next page for more information on mapping.

3.3.10.

Tapping the MAPPING touch point on the Network Setting screen will display the Network Mapping options for the NCD.

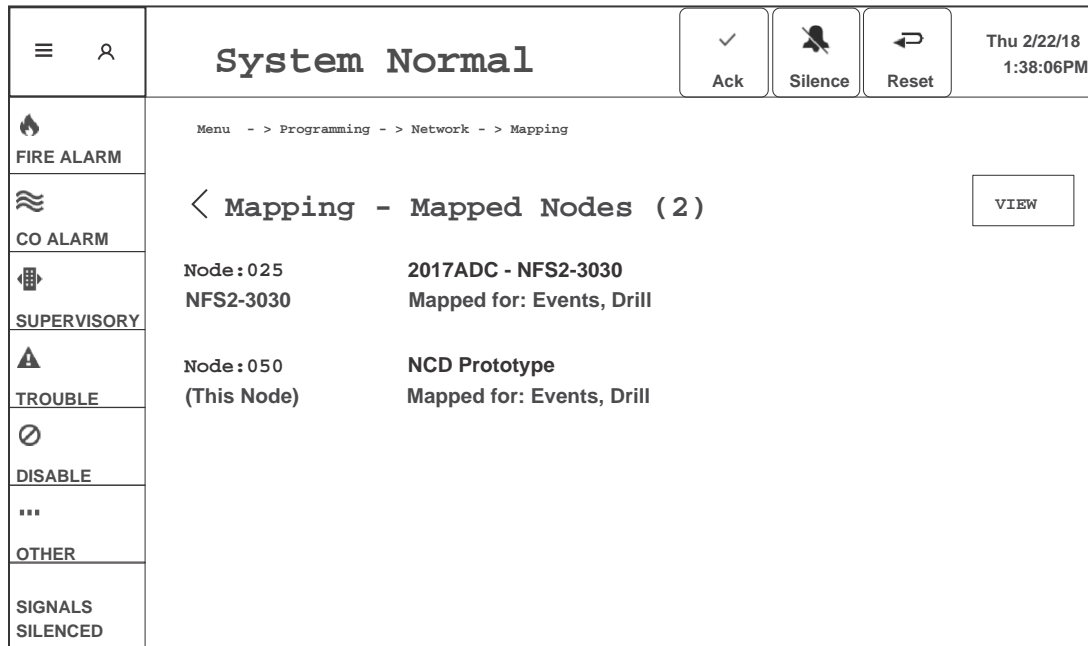

Tap the touch point view to display the menu view options for the network nodes connected to the NCD.

All Online Nodes.

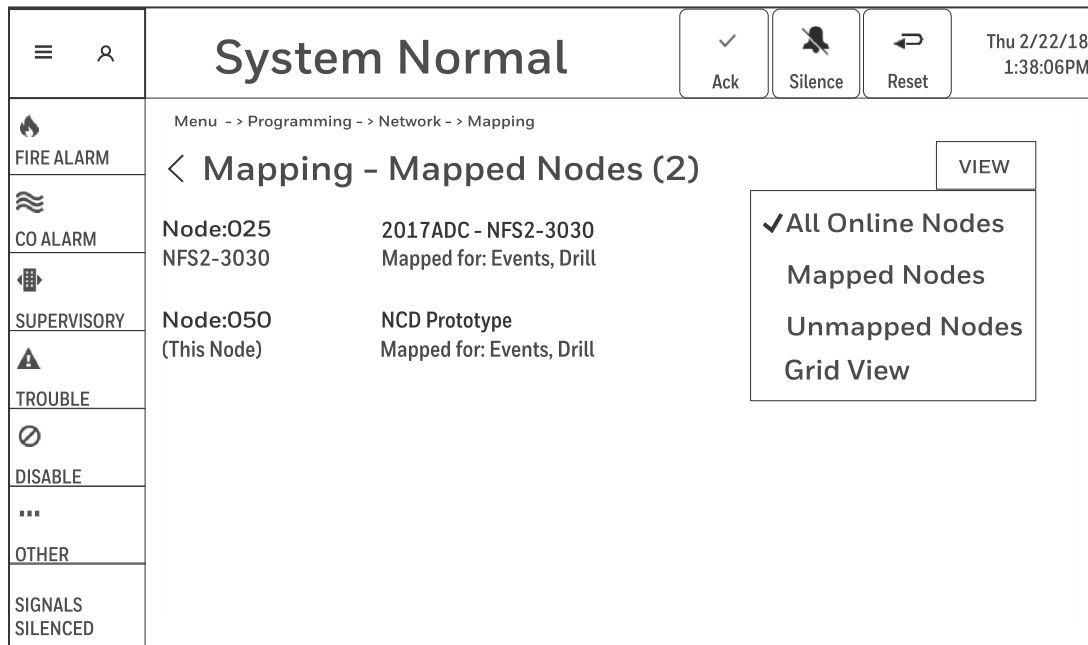

Allows the user to view all nodes that are on-line and will indicate whether or not they are mapped nodes. It allows the user to view what nodel(s) the panel is mapped to.

Grid View

Allows the user to view and map/unmap networked nodes. If the user is not logged in a popup will appear stating “not authorized”

☰	System Normal																			✓ Ack	🔇 Silence	↶ Reset	Tue 01/22/18 02:38:06PM Master
🔥 FIRE ALARM	Menu -> Programming -> Network -> Mapping																						
	< Mapping: Grid View																						
	1	2	3	4	5	6	7	8	9	10	11	12	13	14	15	16	17	18	19	20			
🌊 CO ALARM	21	22	23	24	25	26	27	28	29	30	31	32	33	34	35	36	37	38	39	40			
📡 SUPERVISORY	41	42	43	44	45	46	47	48	49	50	51	52	53	54	55	56	57	58	59	60			
⚠️ TROUBLE	61	62	63	64	65	66	67	68	69	70	71	72	73	74	75	76	77	78	79	80			
🚫 DISABLE	81	82	83	84	85	86	87	88	89	90	91	92	93	94	95	96	97	98	99	100			
*** OTHER	101	102	103	104	105	106	107	108	109	110	111	112	113	114	115	116	117	118	119	120			
📶 SIGNALS SILENCED	121	122	123	124	125	126	127	128	129	130	131	132	133	134	135	136	137	138	139	140			
	141	142	143	144	145	146	147	148	149	150	151	152	153	154	155	156	157	158	159	160			
	161	162	163	164	165	166	167	168	169	170	171	172	173	174	175	176	177	178	179	180			
	181	182	183	184	185	186	187	188	189	190	191	192	193	194	195	196	197	198	199	200			
	201	202	203	204	205	206	207	208	209	210	211	212	213	214	215	216	217	218	219	220			
	221	222	223	224	225	226	227	228	229	230	231	232	233	234	235	236	237	238	239	240			

Mapped Nodes

Allows the user to view all the networked nodes mapped to this panel. It will show the node number and the mapping of each panel.

Unmapped Nodes

Allows the user to view the network nodes that are not mapped to this panel.

3.3.11. USER LOGIN

The user login touch point is always present and located in the upper left hand corner of the screen. This login will allow access for various programming options and programming levels on the NCD.

In the TOC view, this section is a child of Mapping - which is not true. User Login is always available from the Main window. Since Programming requires a user login, suggest moving this section under Programming.

3.3.11.1. Adding and Removing a User

A user name cannot exceed 16 alpha numeric characters.

Adding a User

- Tap Add User
- Enter User name
- Enter password and password confirmation
- Tap Add User

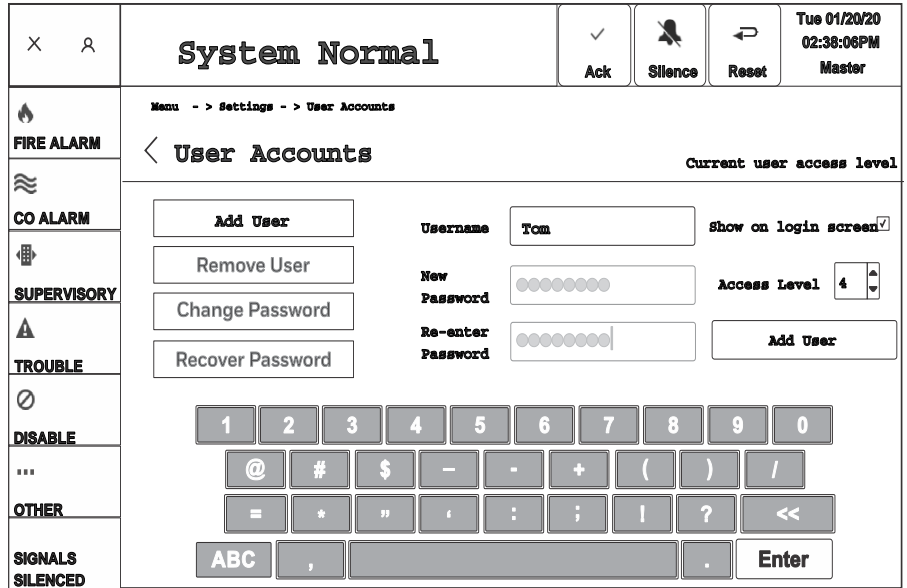

Removing a User

- At the main menu tap on the touch point setting and then users.
- In the users menu tap on the remove user touch point
- The virtual keyboard will appear enter the user name to be removed then tap on remove user.

Changing Password and Recovering a Password should be under ...->Settings->User Accounts

The user has the ability to change and recover the password in the User Login screen.

3.3.11.2. Changing the Password

- At the main menu tap on the touch point settings and then users.
- Once in the user menu tap on change password.
- The virtual keyboard will appear.
- Enter the current password.
- Enter the new password.
- re-enter the new password.
- Tap on change password to save the new password.

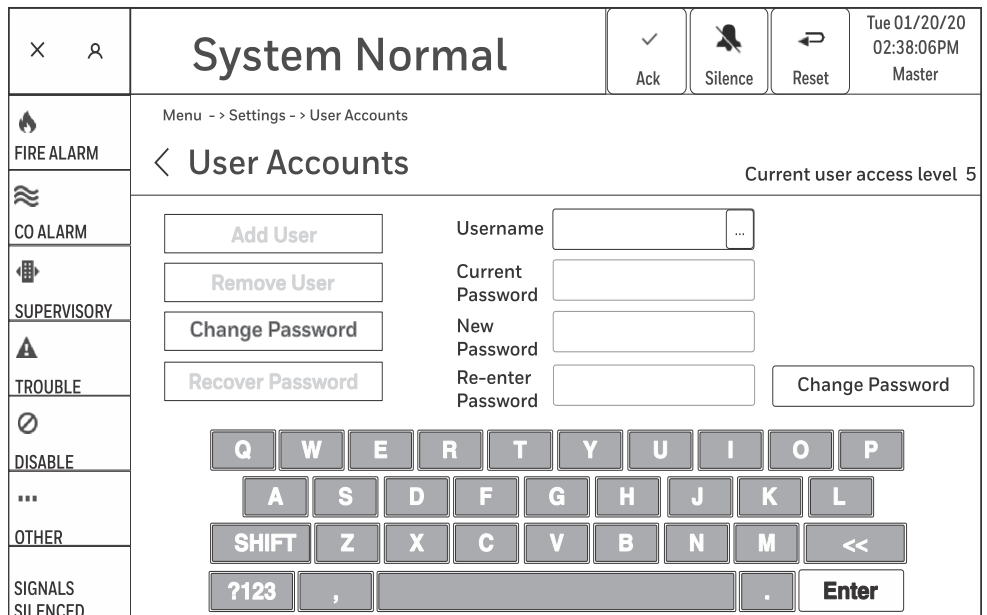

Recovering a Master Password for firmware version prior to 5.0

- At the main menu tap on settings and users.
- Once in the user accounts menu tap on recover password and then tap on generate recovery code.
- Record the code and contact NOTIFIER Technical Support.
- Once the temporary password has been received and entered into the panel the master password must be changed.
- The temporary password is only active for five days. Once it expires the recovery process must be re-initiated.

Recovering a Master Password for firmware version 5.0 or higher.

- To recover a master password on firmware version 5.0 or higher a USB drive is required. Follow the steps below to recover the master password.
- At the main menu, tap on settings and users.
- Once in the users menu, insert the USB drive, tap on recover password and follow the prompts.
- A password recovery file will upload to the USB drive.
- Once the password change file has been received and uploaded to the panel, the master password must be changed.
- The password change file is only active for five days. Once it expires the recovery process must be re-initiated.
- Send an email to notifier.tech@honeywell.com to initiate the NOTIFER password agreement process.

3.3.11.3. Levels of Programing Access

There are four access levels (1-4) that can be assigned to 49 of the 50 programmable users. Additionally, there is a master user whose access level is fixed at level five (5). Only one level five user allowed. Refer to User Level Permissions for default information on user level capabilities. Through the user setup screen Actions defaulted to yes can be changed to no. This applies to user levels 4 though 1. Refer to VeriFire Tools for more information on user accounts.

User Level Permissions

- Master User (level 5 user)
- Admin User (level 4 user)
- Technician User (level 3 user)

- Building Maint User (level 2 user)

- A Level 2 user can be programmed to be logged in by default when there in no other user logged in The default user name is set at “General Access”
- A Level 2 user can also be programmed to be logged in via a key-switch wired to the back of the panel. The default user name is set at “Key-switch Access”

- System Operator (level 1 user)

- A Level 1 user can be programmed to be logged in by default when there is no other user logged in. The default user name is set at “Public Access”

*All user names can be customized to a unique user name in VeriFire Tools. User Level Programming Capabilities

Action	Master (Level 5)	Level 4	Level 3	General Access (Level 2)	Public Access (Level 1)
Acknowledge	Yes	Yes	Yes	Yes	Yes
Signal Silence	Yes	Yes	Yes	Yes	Yes
Reset	Yes	Yes	Yes	Yes	Yes
Enable/Disable	Yes	Yes	Yes	Yes	No
Modify Point Label	Yes	Yes	Yes	No	No
Change Password	All Users	Individual Level 4 All Level 3 and 2	Individual Level 3 All Level 2	Individual Level 2	N/A
Drill	Yes	Yes	Yes	Yes	Yes
Read Status	Yes	Yes	Yes	Yes	Yes
Force ON/OFF	Yes	Yes	Yes	No	No
Change Time/Date	Yes	Yes	Yes	No	No
Set Network Configuration	Yes	Yes	No	No	No
Ability to Revoke Other Users	Yes	No	No	No	No
View General History	Yes	Yes	Yes	Yes	Yes
View Sensitive History	Yes	No	No	No	No
Export History	Yes	Yes	Yes	No	No
Scroll the Display	Yes	Yes	Yes	Yes	Yes
Change Node Address and Label	Yes	Yes	No	No	No
Autoprogram SLC	Yes	Yes	No	No	No

Action	Master (Level 5)	Level 4	Level 3	General Access (Level 2)	Public Access (Level 1)
Modify Node Map	Yes	Yes	No	No	No
Lamp Test	Yes	Yes	Yes	Yes	
Service Mode	Yes	Yes	No	No	No
Import Firmware From Flash Drive	Yes	Yes	No	No	No
Allow Commands From AIO	Yes	Yes	Yes	Yes	Yes

Table 3.1 User Level Permissions

3.3.11.4. Regional Settings

- Chicago

Drill will be disabled locally.

Signal Silence will be disabled locally.

System Reset will only be allowed when all events have been acknowledged.

Annunciator Control Modules and SLC modules should not be programmed for a drill or signal silence Mode or Type Code.

3.4 TEST/DIAGNOSTICS

Tapping on the Test/Diagnostics touch point on the menu screen will display diagnostic, lamp test, history, export diagnostics, clear database, clear licenses, and reboot options for the NCD

3.4.1. DIAGNOSTICS

Tap the diagnostics touch point to view the Circuit Board temperature and the CPU temperature. It displays the highest circuit board temperature and the highest CPU temperature, along with AIO communication statistics. Each may be reset by tapping on the reset touch point.

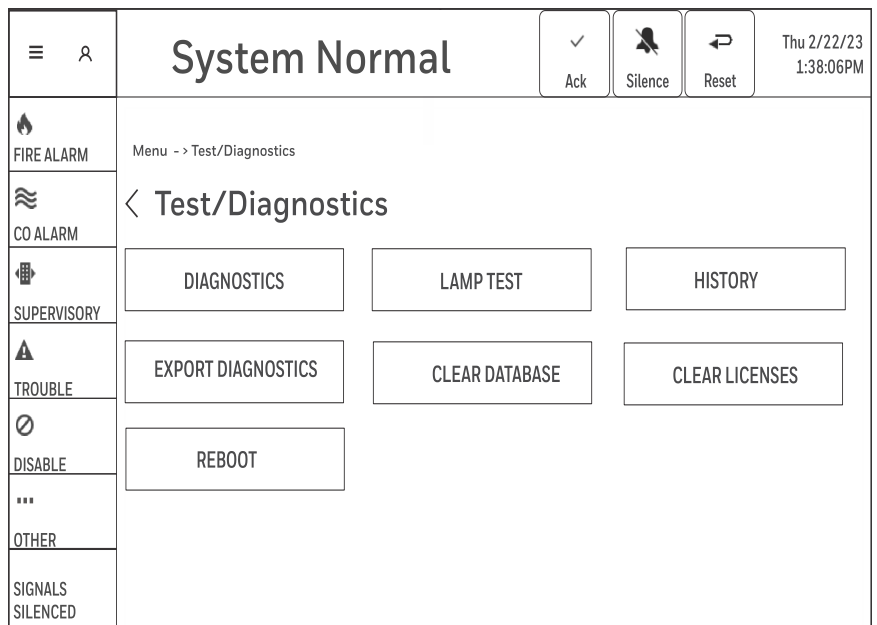

3.4.2. LAMP TEST

Tap the lamp test touch point to turn on all pixels on the screen. This will illuminate the entire screen as well as the AC Power and Off Normal LED for approximately four seconds. During this time a tone will sound. A black spot on the screen will indicate that a pixel is out.

3.4.3. VIEW HISTORY

Tap the history touch point allows the user to view the panel history. History views may also be filtered. Tap on the touch point filter. A touch point for search and clear will appear along with a virtual keyboard. Tap in a date under date range to search a specific date range. Tap in a keyword in the contains text section to search the history for particular text. To clear a search tap the touch point clear. Tap on the exclude background activations check box to select that feature. Tap again to clear the field.

		System Normal		✓	🔇	↶	Tue 01/22/18 02:38:06PM Master																																																		
☰	🔍			Ack	Silence	Reset																																																			
🔥	FIRE ALARM	Menu -> Test/Diagnostics -> History																																																							
📶	CO ALARM	< History																																																							
👤	SUPERVISORY	SEARCH CLEAR																																																							
⚠️	TROUBLE	Date range: between MM/dd/yyyy and MM/dd/yyyy																																																							
🚫	DISABLE	July 2019																																																							
⋮	OTHER	<table border="1"> <thead> <tr> <th>Sun</th> <th>Mon</th> <th>Tue</th> <th>Wed</th> <th>Thu</th> <th>Fri</th> <th>Sat</th> </tr> </thead> <tbody> <tr> <td></td> <td>1</td> <td>2</td> <td>3</td> <td>4</td> <td>5</td> <td>6</td> </tr> <tr> <td>7</td> <td>8</td> <td>9</td> <td>10</td> <td>11</td> <td>12</td> <td>13</td> </tr> <tr> <td>14</td> <td>15</td> <td>16</td> <td>17</td> <td>18</td> <td>19</td> <td>20</td> </tr> <tr> <td>21</td> <td>22</td> <td>23</td> <td>24</td> <td>25</td> <td>26</td> <td>27</td> </tr> <tr> <td>28</td> <td>29</td> <td>30</td> <td>31</td> <td>1</td> <td>2</td> <td>3</td> </tr> <tr> <td>4</td> <td>5</td> <td>6</td> <td>7</td> <td>8</td> <td>9</td> <td>10</td> </tr> </tbody> </table>						Sun	Mon	Tue	Wed	Thu	Fri	Sat		1	2	3	4	5	6	7	8	9	10	11	12	13	14	15	16	17	18	19	20	21	22	23	24	25	26	27	28	29	30	31	1	2	3	4	5	6	7	8	9	10	
Sun	Mon	Tue	Wed	Thu	Fri	Sat																																																			
	1	2	3	4	5	6																																																			
7	8	9	10	11	12	13																																																			
14	15	16	17	18	19	20																																																			
21	22	23	24	25	26	27																																																			
28	29	30	31	1	2	3																																																			
4	5	6	7	8	9	10																																																			
🔇	SIGNALS SILENCED																																																								

3.4.4. EXPORT DIAGNOSTICS

Tap the Export Diagnostics touch point to export diagnostic data to a USB flash drive. The

History will be exported as a compressed “.tar” file. To extract the exported history you may use: 7-Zip, Winzip, WinRAR or any program compatible with “.tar” files. Once its extracted you can find the history file in “.csv” format.

3.4.5. CLEAR DATABASE

Tap the Clear Database touch point to clear panel programming. Requires reprogramming with VeriFire Tools. Refer to the VeriFire Tools help files for more information on panel programming.

3.4.6. CLEAR LICENSES

Tap the Clear Licenses touch point to remove all licenses from the NCD.

3.4.7. REBOOT

Tap the Reboot touch point to reboot the NCD.





















3.5 CUSTOM ACTIONS

Custom Actions are virtual buttons that can be mapped and employed to manually control common system commands such as enable/disable points. Custom Actions are completely programmable and can be user defined within VeriFire Tools. To disable a group of points, , or zones tap on the touch point custom actions, select the point to disable and tap on the touch point disable. The enable touch point will be grayed out if the point is enabled. Custom Action Button are programmable soft buttons available on the FACP, NCD or RLD. They can be mapped to different endpoints (modules, general or logic zones , detectors) to Enable/disable or Turn on/Turnoff the end points. They can be used to simplify and make routine testing faster. Refer to Licensing section for details on whats available on the base system and how to expand number of custom action buttons. The N16/NCD supports up to 32 custom action buttons

The N16/NCD supports up to 1000 different end points per panel.

You may map all 1000 endpoints to a single custom action button or distribute them across 32 custom action buttons

☰	🔍	System Normal			✓ Ack	🔇 Silence	↶ Reset	Tue 01/22/18 02:38:06PM Master
🔥 FIRE ALARM	Menu - > Custom							
	< Custom Actions							
🌊 CO ALARM	Disable N210	0%	0%	0%	ENABLE	DISABLE		
	Detectors Modules	Trouble	Disable	Active				
📡 SUPERVISORY	Disable N210	0%	0%	0%	ENABLE	DISABLE	TURN ON	TURN OFF
⚠️ TROUBLE	Zones	Trouble	Disable	Active				
	- N210Z1	⚠️	🚫	⬆️				
🚫 DISABLE	- N210Z10	⚠️	🚫	⬆️				
	- N210Z100	⚠️	🚫	⬆️				
⋮ OTHER	- N210Z200	⚠️	🚫	⬆️				
	- N210Z300	⚠️	🚫	⬆️				
	- N210Z400	⚠️	🚫	⬆️				
📡 SIGNALS	- N210Z500	⚠️	🚫	⬆️				
🔇 SILENCED	- N210Z600	⚠️	🚫	⬆️				

 		 TROUBLE		 Block Ack	 Silence	 Reset	Tue 01/22/23 02:38:06PM Master
Authorized Personnel: Ack each event. Contact service provider to investigate condition.							
 UNACKNOWLEDGED TROUBLES (5)							
 FIRE ALARM							
 CO ALARM							
 SUPERVISORY							
 5 TROUBLE	 TROUBLE	System	MAN. EVAC RECEIVED Node 234				Thu 02/22/18 1:52:57 PM N234T109
	 TROUBLE	System	MAN. EVAC RECEIVED Node 234				Thu 02/22/18 1:52:57 PM N225T109
 DISABLE	 TROUBLE	System	MAN. EVAC RECEIVED Node 234				Thu 02/22/18 1:52:57 PM N215T109
 OTHER	 TROUBLE	System	MAN. EVAC RECEIVED Node 234				Thu 02/22/18 1:52:57 PM N142T109
 SIGNALS SILENCED	 TROUBLE	System	MAN. EVAC RECEIVED Node 234				Thu 02/22/18 1:52:57 PM N234T109
 DRILL (HOLD)							

3.5.1. ENABLE POINTS

To enable a group of points or zones from the main menu tap on the touch point custom actions, select the group of points to enable and tap on touch point enable. The disable touch point will be grayed out if the group of points is disabled and there will be a trouble message on the panel stating which point is disabled.

3.5.2. TURN ON/OFF POINTS

To turn ON or OFF a group of points from the main menu tap on the touch point custom actions, select the point to turn ON/OFF and tap on either turn on or turn off. If the point is grayed out the point is OFF.

 NOTE: The maximum number of actions that can be performed at one time is eight (8).

SECTION 4: OPERATION

This section describes the NCD operation and how events are portrayed.







EVENT	SYMBOL	DISPLAY INDICATION
Fire Alarm		Fire Alarm is indicated in RED
CO Alarm		CO Alarm is indicated in BLUE
Supervisory		Supervisory is indicated in YELLOW
Trouble		Trouble is indicated in YELLOW
Disabled Point		Disabled Point is indicated in YELLOW
Other Event		Other is indicated as the highest priority that is not categorized.
Drill		Drill is indicated as a Trouble

Table 4.1 Event Symbols

4.1 RESPONDING TO A FIRE ALARM

To acknowledge the event and silence the NCD sounder, do the following:

- The Informational Text Area on the screen will indicate step by step how to acknowledge and silence the event.
- Tap on the acknowledge touch point located in the Header Bar, which will be highlighted in blue. A check mark will appear next to the acknowledged event. Acknowledge will need to be tapped for each

Fire Event. Block Acknowledge is not available. Once all the events have been acknowledged, the blue highlight indicator will move from the acknowledge touch point to the silence touch point.

- Tap on the silence touch point located in the Header Bar. The silence icon in the Alert Bar will illuminate yellow once the NCD has silenced and all silenceable outputs will turn off.
- Investigate and correct the condition that activated the Fire Alarm.
- Once the NCD has been silenced the blue highlight indicator will move from the silence touch point to the reset touch point.
- Tap the reset touch point located in the Header Bar to return the NCD to normal operations.

4.2 CARBON MONOXIDE ALARM

An active Carbon Monoxide Alarm will display as follows on the NCD:

- Produces a pulsed audible tone.
- co alarm appears in the Header Bar.
- co alarm illuminates in the Alert Bar as a blue color indicator and provides CO event counts.
- Illuminates the yellow Off Normal LED.
- Displays co alarm and specific device information in the Events List.

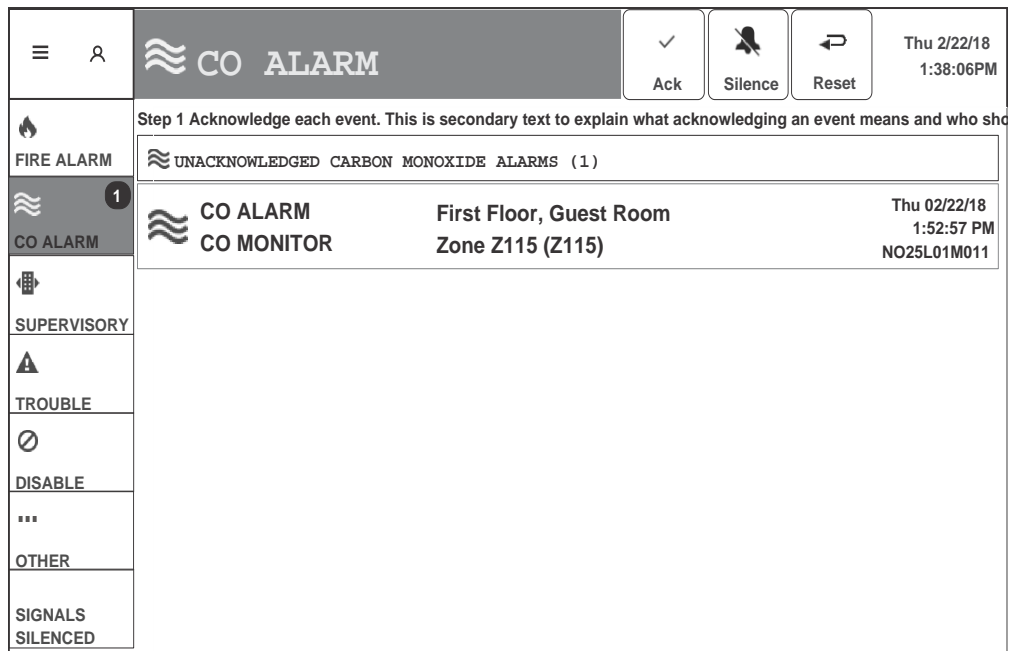

- Displays information on how to react to the event in the Instructional Text Area.
- Latches the NCD in CO Alarm.

4.2.1. RESPONDING TO A CARBON MONOXIDE ALARM

To acknowledge the event and silence the NCD sounder do the following:

- The Informational Text Area on the screen will indicate step by step what needs to be done to acknowledge and silence the event.

- Tap on the acknowledge touch point located in the Header Bar. The acknowledge touch point will be highlighted in blue. A check mark will appear next to the acknowledged event. Once all the events have been acknowledged the blue highlight indicator will move from the acknowledge touch point to the silence touch point.
- Block Acknowledge allows for multiple events to be acknowledged at once.
- Tap on the silence touch point located in the Header Bar. The silence icon in the Alert Bar will illuminate yellow once the NCD is silenced all silenceable outputs will turn off.
- Investigate and correct the condition that activated the CO Alarm point.
- Once all events on the NCD have been silenced the blue highlight indicator will move from the silence touch point to the reset touch point.
- Tap the reset touch point located in the Header Bar to return the NCD to normal operations.

4.3 SUPERVISORY ACTIVATION

A Supervisory activation will display as follows on the NCD.

- Produces a warbling audible tone.
- supervisory appears in the Header Bar.
- supervisory illuminates on the Alert Bar as a yellow color indicator and provides Supervisory event counts.
- Illuminates the yellow off normal LED.
- Displays supervisory and specific device information in the Events List.
- Displays information on how to react to the event in the Instructional Text Area.

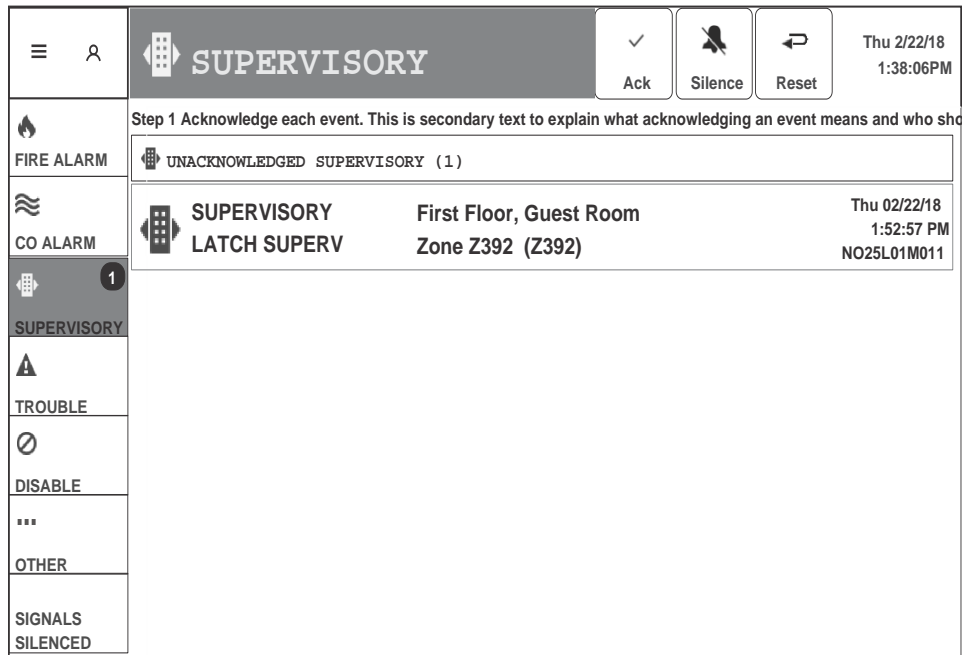

4.3.1. RESPONDING TO A SUPERVISORY ACTIVATION

To acknowledge the event and silence the NCD sounder do the following:

- The Informational Text Area on the screen will indicate step by step what needs to be done to acknowledge and silence the event.
- Tap on the acknowledge touch point located in the Header Bar. The acknowledge touch point will be highlighted in blue. A check mark will appear next to the acknowledged event.
- Tap on the Silence touch point located in the Header Bar. The silence icon in the Alert Bar will illuminate yellow once the NCD is silenced. All silenceable outputs will turn off.
- Block acknowledge allows for multiple events to be acknowledged at once.
- Investigate and correct the condition that activated the Supervisory point.
- Once all the events have been acknowledged the blue highlight indicator will move from the acknowledge touch point to the silence touch point.

For a non-latching event, the NCD will return to normal once the supervisory condition is corrected.

For a latching event, tap on the reset touch point located in the Header Bar to return the NCD to normal.

4.4 TROUBLE EVENT

A System Trouble, Point Trouble, electrical or mechanical fault will display as follows on the NCD if no higher priority unacknowledged events exists on the system.:

- Produces a pulsed audible tone.
- Turns on the Trouble Relay.
- Trouble appears in the Header Bar.
- Trouble appears in the Alert Bar as a yellow color indicator and provides Trouble event counts.
- Turns on the off normal LED
- Displays Trouble and specific device information in the Events List.

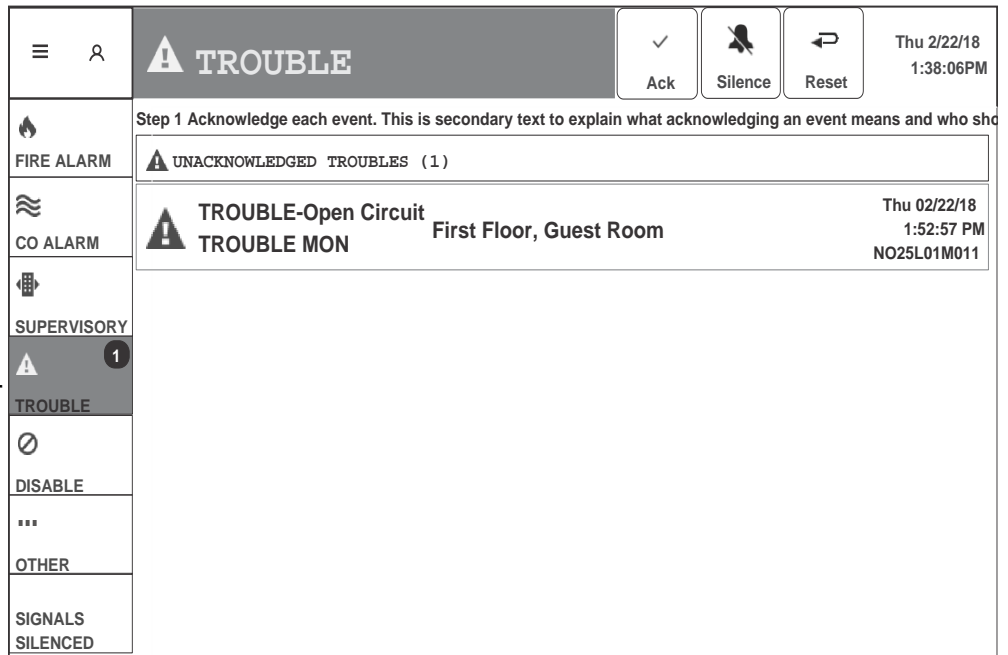

- Displays information on how to react to the event in the Informational Text Area.

 NOTE: If an unacknowledged, higher priority event exists, the NCD will retain the indications of the higher priority event, such as the LED, audible tone, etc. The Trouble Relay, and flashing event LED will still react at the time of the event.

4.4.1. RESPONDING TO A TROUBLE EVENT

To acknowledge the event and silence the NCD sounder do the following:

- The Informational Text Area on the screen will indicate step by step what needs to be done to acknowledge and silence the event
- Tap on the acknowledge touch point located in the Header Bar. The acknowledge touch point will be highlighted in blue. A check mark will appear next to the acknowledged event.
- Block acknowledge allows for multiple events to be acknowledged at once.
- Investigate and correct the condition that initiated the trouble condition.

4.5 DISABLED POINT

When a system point is disabled it will display as follows on the NCD:

- Produces a pulsed audible sound.
- Turns on the trouble Relay.
- Disabled appears in the Header Bar.
- Disabled illuminates in the Alert Bar as a yellow icon and indicated device event count.
- Illuminates the yellow off normal LED.
- Displays disabled and specific point information in the Events List.

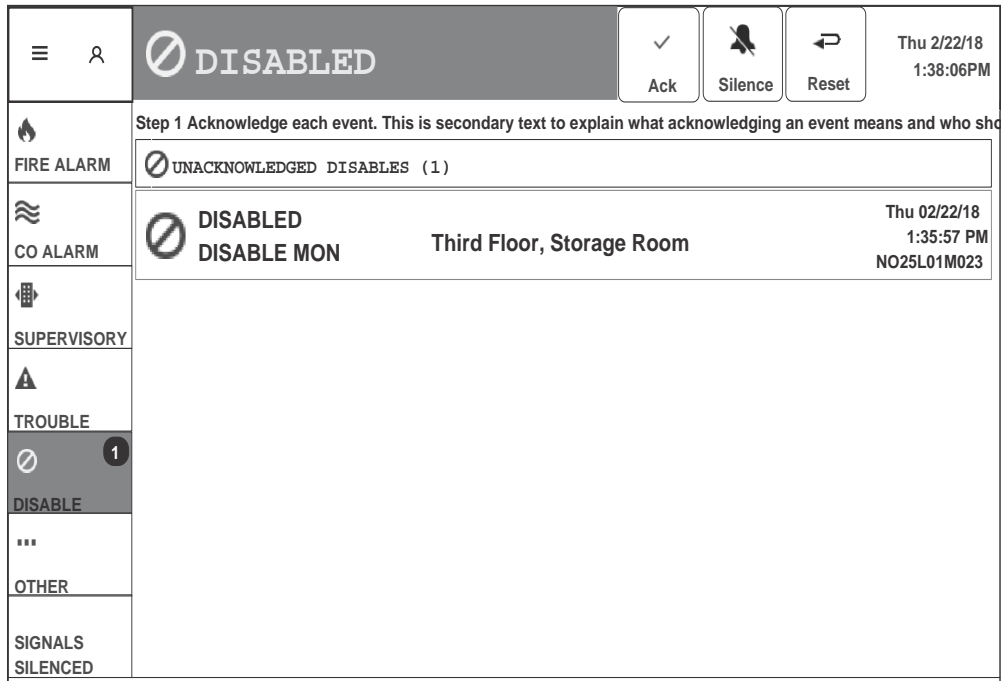

- Displays information on how to react to the event in the Informational Text Area.



 NOTE: If an unacknowledged, higher priority event exists, the NCD will retain the indications of the higher priority event, such as the LED, audible tone, etc. The Trouble Relay, flashing event LED will still react at the time of the event

4.5.1. RESPONDING TO A DISABLED POINT

To acknowledge the disabled point and silence the NCD sounder do the following:

- The Informational Text Area on the screen will indicate step by step what needs to be done to acknowledge and silence the event.
- Tap on the acknowledge touch point located in the Header Bar. The acknowledge touch point will be highlighted in blue. A check mark will appear next to the acknowledged event.
- Block acknowledge allows for multiple events to be acknowledged at once.
- Enable the disabled point.

4.6 OTHER

☰	🔍	 SECURITY ALARM	✓ Ack	🔇 Silence	↶ Reset	Thu 2/22/18 1:38:06PM
Step 1 Acknowledge each event. This is secondary text to explain what acknowledging an event means and who should acknowledge it.						
🔥 FIRE ALARM	UNACKNOWLEDGED SECURITY ALARMS (1)					
🌊 CO ALARM	 SECURITY ALARM  SECURITY L	First Floor, Guest Room Zone Z553 (Z553)	Thu 02/22/18 1:52:57 PM NO25L01M011			
📡 SUPERVISORY						
⚠️ TROUBLE						
⊘ DISABLE						
⋮ OTHER	1					
📶 SIGNALS SILENCED						

Events listed as Other are as follows:

- CO Pre-Alarm (blue).
- Critical Processes (yellow).
- Security (blue).

- Pre-Alarm (red).
- Hazard/Weather Alert (Yellow).

When more than one of these conditions have been activated they will be listed in order of priority. CO-Pre Alarm will be listed first, followed by Critical Processes, Security, Pre-Alarm and Hazard/Weather Alert.

4.6.1. RESPONDING TO AN OTHER EVENT

To acknowledge an Other event and silence the NCD sounder do the following:

- The Informational Text Area on the screen will indicate step by step what needs to be done to acknowledge and silence the event.
- Tap on the acknowledge touch point located in the Header Bar. The acknowledge touch point will be highlighted in blue. A check mark will appear next to the acknowledged event.
- Block Acknowledge allows for multiple events to be acknowledged at once.
- Tap on the silence touch point located in the Header Bar. The silence icon in the Alert Bar will illuminate yellow once the NCD is silenced.
- Once all the events have been acknowledged the blue highlight indicator will move from the acknowledge touch point to the silence touch point.
- Tap reset for an latched event.

NCD Operating Instructions

SECTION 1 OPERATING INFORMATION

NORMAL STANDBY OPERATION

1. System Normal indicated on Header Bar.
2. Green POWER LED lit steadily
3. No Red FIRE ALARM indication.
4. No Blue CO ALARM indication.
5. No Yellow SUPERVISORY, TROUBLE, DISABLE, OTHER or SIGNALS SILENCED indications.
6. Off Normal LED off

ALARM CONDITION

1. Red FIRE ALARM, Blue CO ALARM, and/or Yellow OTHER indication (s) on the touch screen display.
2. Alarm signaling devices activated.
3. Alarm information is visible on the touch screen display
4. Off Normal LED illuminated

PRE-ALARM CONDITION.

Alarm Reset. After locating and correcting the alarm condition, reset the control panel by tapping the RESET touch point.

Trouble Condition. Activation of trouble signal under normal operation indicates a condition that requires **immediate** attention. Contact your local service representative. Silence the audible signal by tapping the ACK touch point. The trouble indication will remain on the NCD until the trouble is cleared.

SECTION 2 NCD TOUCH POINT FUNCTIONS

ACK (ACKNOWLEDGE). This silences the piezo sounder, steadies the flashing event on the header bars, and changes each condition to Acknowledged. If more than one event exists, it advances the display to the next item and displays it until ACKNOWLEDGE is tapped again. Only one tap is necessary for non-fire, trouble, or supervisory signals. Fire alarms require one tap for each activation.

SILENCE. The SILENCE touch point turns off all silenceable circuits and illuminates the SIGNALS SILENCED indicator on the Alert Bar. A subsequent alarm will then resound the system.

DRILL. The NCD waits for the Drill switch to be pressed for 2 seconds (to prevent accidental activations), then turns on all silenceable circuits (all control modules/panel circuits that are programmed silenceable), and turns off the SIGNALS SILENCED LED. This event shows on the LCD, printer, and History file.

RESET. Resets the NCD in standalone applications. Resets the associated panel when enabled in network applications.

LAMP TEST. A Lamp Test can be performed via the Test/Diagnostics option on the NCD. Press the Menu option and select Test/Diagnostics. Tap the LAMP TEST touch point to turn on all pixels on the screen, sound the piezo, and illuminate the Power and Off Normal Event LEDs for four (4) seconds.

SECTION 3 EVENT INDICATORS

Fire Alarm. Red indication on the Alert Bar and flashes on the Header Bar when one or more alarms occur. Illuminates steadily after alarms are acknowledged, and turns off when RESET is pressed after the alarm(s) clear.

CO Alarm. Blue indication on the Alert Bar and flashes on the Header Bar for a CO alarm. Illuminates steadily after alarms are acknowledged, and turns off when RESET is pressed after the alarm(s) clear.

Supervisory. Yellow Indication that flashes on the Alert Bar when a Supervisory or Tamper condition occurs, such as a sprinkler valve tamper condition. The indication illuminates steady after conditions are acknowledged, and turns off when the conditions are cleared. A Tamper indication will latch until RESET is pushed. RESET is required for any latched event.

Security. A blue indication on the Alert Bar and flashes on Header Bar when a security activation occurs. Illuminates steadily after acknowledge is pressed, and turns off when the security activation is cleared. RESET is required for any latched event.

Trouble. Yellow indication on the Alert Bar and flashes on the Header Bar when one or more troubles occur. Illuminates steadily when ACKNOWLEDGE is pressed, and turns off when all trouble conditions are cleared.

Disable. Yellow indication on the Alert Bar and flashes on the Header Bar when one or more points are disabled. The display will indicate which points have been disabled. Turns off when points are re-enabled.

Other Event. Yellow indication that flashes on the Alert Bar when a Critical Process or Hazard /Weather Alert occurs. When a CO Pre-alarm occurs, indication flashes blue, and a Pre-alarm indication will flash red. Illuminates steady when Acknowledge is pressed, and turns off when the condition is cleared.

Signals Silenced. Yellow indication that illuminates after SIGNALS SILENCED has been pressed. Turns off when DRILL or RESET is pressed.

SECTION 4 LED INDICATORS

Power. Green LED which illuminates when primary power is applied to the NCD.

Off Normal. Yellow LED which illuminates when any off normal event is present on the NCD.

SECTION 5 NCD AUDIBLE SOUNDER

Alarm. A continuous sounding tone.

Trouble, Disable, Pre-alarm. One beep per second.

CO-Alarm. Four beeps per second.

Supervisory. Four beeps per second.

Security. Eight beeps per second.

Other Event. Four beeps per second.

SECTION 6 PERIODIC TESTING AND MAINTENANCE

To ensure proper and reliable operation, system inspection and testing should be scheduled monthly, or as required by NFPA 72 or local fire codes. A qualified Service Representative should perform testing.

Before Testing: Notify fire department if alarm condition is transmitted. Notify facility personnel of the test so alarm sounding devices are ignored during the test period.

After Testing: Notify all fire, and/or building personnel when testing is complete. *Re-connect releasing devices.*

SECTION 7 LOCAL SERVICE REPRESENTATIVE:

NAME: _____

ADDRESS: _____

TELEPHONE NUMBER: _____

Cut along dotted line.